

UNIT LEVEL MAINTENANCE HANDBOOK SINGGARS ICOM GROUND RADIOS

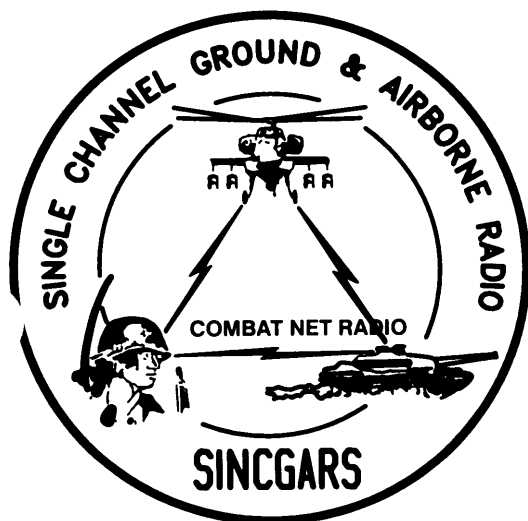

INTRODUCTION	PAGE 1-1
MANPACK RADIO	PAGE 2-1
VEHICUIAR RADIOS	PAGE 3-1
CABLE SCHEMATICS	PAGE 4-1
SELECTED GRAPHICS	PAGE 5-1

GROUND ICOM RADIO SETS

- AN/PRC-119A (NSN 5820-01-267-9482) (EIC: L2Q),
- AN/VRC-87A (NSN 5820-01-267-9480) (EIC: L22),
- AN/VRC-88A (NSN 5820-01-267-9481) (EIC: L23),
- AN/VRC-89A (NSN 5820-01-267-9479) (EIC: L24),
- AN/VRC-90A (NSN 5820-01-267-5105) (EIC: L25),
- AN/VRC-91A (NSN 5820-01-267-9478) (EIC: L26),
- AN/VRC-92A (NSN 5820-01-267-9477) (EIC: L27)

Approved for public release; distribution is unlimited.

BATTERY WARNINGS

+ The SINCGARS manpack radio uses a lithium battery as the main power source. All SINCGARS radios use a lithium battery for the HUB, and the ANCD uses three 3-volt lithium batteries for power. Lithium batteries contain pressurized toxic, sulfur dioxide gas.

+ For safety's sake, follow these rules when handling lithium batteries:

++ **Do NOT** abuse lithium batteries in any way.

++ **Do NOT** heat, short circuit, crush, puncture, or cut them.

++ **Do NOT** use any lithium battery showing signs of damage.

++ **Do NOT** test them for state of charge (maintainer task only).

++ **Do NOT** attempt to recharge lithium batteries.

++ **Do NOT** place them in ordinary trash; turn in used batteries unit supply, or when operational follow unit SOP regarding disposal.

++ **Do NOT** use a Halon-type fire extinguisher on a lithium fire

++ **Do NOT** store batteries in unused equipment.

++ **Do NOT** store lithium batteries with other hazardous materials.

++ **Do NOT** store lithium batteries near flame or heat sources.

+ If battery compartment becomes hot to touch, if it hisses or makes a burping sound, or you smell an irritating gas:

++ **DO** turn off equipment.

++ **DO** let equipment cool for at least an hour.

++ **DO**, after equipment is cool, remove battery/batteries.

++ **DO** install new battery/batteries; resume maintenance activities.

+ If you experience a safety hazard or incident, notify your unit Safety Officer; file Form 368 (Product Quality Deficiency Report); and notify CECOM Safety Office, Ft. Monmouth, NJ. (DSN 995-31 12).



ELECTRICAL SHOCK



SAFETY STEPS

1

DO NOT TRY TO PULL OR GRAB THE INDIVIDUAL.

2

IF POSSIBLE, TURN OFF THE ELECTRICAL POWER.

3

IF YOU CANNOT TURN OFF THE ELECTRICAL POWER, PULL, PUSH, OR LIFT THE PERSON TO SAFETY USING A DRY WOODEN POLE OR A DRY ROPE OR SOME OTHER INSULATING MATERIAL.

4

SEND FOR HELP AS SOON AS POSSIBLE.

5

AFTER THE INJURED PERSON IS FREE OF CONTACT WITH THE SOURCE OF ELECTRICAL SHOCK, MOVE THE PERSONA SHORT DISTANCE AWAY AND IMMEDIATELY START ARTIFICIAL RESUSCITATION.

WARNING

RF ENERGY IS PRESENT NEAR THE ANTENNA DURING TRANSMISSION, EXCEPT FOR MANPACK RADIO, MAINTAIN AT LEAST 30 INCHES BETWEEN ANTENNA AND PERSONNEL DURING TRANSMISSION.

WARNING

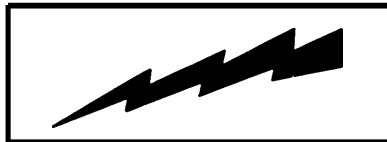

HIGH VOLTAGE

EXISTS AT CONNECTOR J1 ON VEHICULAR MOUNTING ADAPTER. AVOID PERSONAL INJURY; BE SURE J1 IS COVERED OR CAPPED WHEN NOT IN USE.

WARNING

VAA CONNECTOR J1 AND PA MOUNT CONNECTOR J4 HAVE 200 VDC ON PIN F. USE EXTREME CAUTION IN MEASURING VOLTAGE AT J1 OR J4.

DEATH OR SERIOUS INJURY CAN RESULT:

- Z** When antenna tip caps are not installed on antennas,
- Z** When a tied-down antenna hits a fixed object such as an overhead bridge, tree limb, etc. Flying antenna parts might strike nearby personnel.

THIS PAGE INTENTIONALLY BLANK.

UNIT LEVEL MAINTENANCE HANDBOOK GROUND ICOM RADIOS SETS:

- AN/PRC-119A (NSN 5820-01-267-9482) (EIC: L2Q),
- AN/VRC-87A (NSN 5820-01-267-9480) (EIC: L22),
- AN/VRC-88A (NSN 5820-01-267-9481) (EIC: L23),
- AN/VRC-89A (NSN 5820-01-267-9479) (EIC: L24),
- AN/VRC-90A (NSN 5820-01-267-5105) (EIC: L25),
- AN/VRC-91A (NSN 5820-01-267-9478) (EIC: L26),
- AN/VRC-92A (NSN 5820-01-267-9477) (EIC: L27)

REPORTING ERRORS AND RECOMMENDING IMPROVEMENTS

You can help improve this manual. If you find any mistakes, or if you know of a way to improve the procedures, please let us know. Mail your letter, DA Form 2028 (Recommended Changes to Publications and Blank Forms) or DA Form 2028-2 located in back of this manual direct to: Commander, US Army Communications- Electronics Command and Fort Monmouth, ATTN: AMSEL-LC-LM-LT, Fort Monmouth, New Jersey 07703-5007.

In either case a reply will be furnished direct to you.

TABLE OF CONTENTS

Sect	Para	Subject	Page
I		<u>INTRODUCTION</u>	
	1.1	Your "Unit Level Maintenance Handbook"	1-1
	1.2	Scope	1-2
	1.3	Avoiding "False Pulls"	1-2
	1.4	Maintenance Forms, Records, and Reports	1-2
	1.5	Reporting Equipment Improvement Recommendations (EIR)	1-3
	1.6	Reporting Errors and Recommending Improvements	1-3
	1.7	Security Classification and Marking	1-3
	1.8	Destruction of Army Electronics Materiel	1-3
	1.9	Abbreviations Used	1-4
II		<u>MANPACK RADIO</u>	
	2.1	Operational Check (Manpack Radio)	2-1
	Step 1	Preparation	2-1
	Step 2	Power Checks	2-1
	Step 3	RT Self-Test	2-2
	Step 4	Load Checks	2-2
	Step 5	Transmitter Checks	2-3
	Step 6	Receiver Checks	2-4
	2.2	Troubleshooting Guides	2-5
	TSG-1	Variable Will Not Load	2-5
	TSG-2	Low or No Power Output	2-5
	TSG-3	Loss of Sidetone	2-6
	TSG-4	Radio Will Not Operate With Data Devices	2-6

TABLE OF CONTENTS Continued

Sect	Para	Subject	Page
III		<u>VEHICULAR RADIOS</u>	
	3.1	Operational Check (Vehicular Radios)	3-1
	Step 1	Preparation	3-1
	Step 2	Power Checks	3-2
	Step 3	RT Self-Test	3-3
	Step 4	Load Checks	3-4
	Step 5	Transmitter Checks	3-5
	Step 6	Receiver Checks	3-6
	Step 7	Power Amplifier Checks.	3-7
	Step 8	LS-671 Checks	3-8
	3.2	Troubleshooting Guides	3-9
	TSG-1	VAA CB1 Trips When Set to ON	3-9
	TSG-2	VAA DS1 Not Lit When CB1 is Set to ON	3-10
	TSG-3	RT-ALS-671 DS1 Not Lit and VAA DS1 is Lit	3-11
	TSG-4	No Remote Power From RT-BLS-671	3-12
	TSG-5	PA Mount CB1 Trips and VAA DS1 is Lit	3-12
	TSG-6	PA Mount DS1 Not Lit and VAA DS1 is Lit	3-13
	TSG-7	Redisplay Does Not Light and VAA DS1 is Lit	3-13
	TSG-8	Redisplay Reads FAIL	3-14
	TSG-9	COMSEC Alarm Not Heard/Will Not Clear (No External Device)	3-14
	TSG-10	COMSEC Alarm Not Heard/Will Not Clear (External Devices Present)	3-15
	TSG-11	Variable (COMSEC or FH Data) Will Not Load	3-16
	TSG-12	Failed Forward and Reverse Power Check	3-17
	TSG-13	No Sidetone With Forward/Reverse Power Correct	3-17
	TSG-14	Forward Power Incorrect Thru PA in RF Power HI	3-18
	TSG-15	RT-A: Less Than 30W Fwd Pwr Out of PA From 30-43 MHz	3-19
	TSG-16	RT-B: Less Than 30W Fwd Pwr Out of PA From 30-43 MHz	3-20
	TSG-17	RT-A: Less Than 30W Fwd Pwr Out of PA From 43-88MHz	3-21
	TSG-18	RT-B: Less Than 30W Fwd Pwr Out of PA From 43-88 MHz	3-21
	TSG-19	RT SIG Display Incorrect With RF Pwr Set to PA.	3-22
	TSG-20	RT SIG Display Does Not Light When LS-671 PTT is Pressed	3-23
	TSG-21	No Sidetone Heard at LS-671	3-24
	TSG-22	Radio Will Not Operate With Data Devices	3-24
IV		<u>CABLE SCHEMATICS</u>	
	4.1	RF Cable (CG-3856)	4-2
	4.2	RF Cable and W2 (CG-3856)	4-2
	4.3	PA Control Cable (CX-13291)	4-3
	4.4	LS-671 Cable (CX-13292)	4-3
	4.5	RXMT Cable (CX-13298)	4-4
	4.6	Intercom Cable (CX-13300)	4-4
	4.7	M551 Power Cable (CX-13301)	4-5
	4.8	Power Cable (CX-13302)	4-5

TABLE OF CONTENTS Continued

Sect Para	Subject	Page
	<u>CABLE SCHEMATICS</u> Continued	
4.9	Power Cable (CX-13303)	4-6
4.10	Power Cable (CX-13304)	4-6
4.11	Power Cable (CX-13305)	4-7
4.12	Power Cable (CX-13306)	4-7
4.13	DMD (Data) Cable (CX-13308)	4-8
4.14	HYX-57 Cable (CX-13310)	4-8
4.15	MST-20 Adapter Cable (CX-13311) ..	4-9
4.16	PSC-3 Adapter Cable (CX-13312) ..	4-9
4.17	VIC Interface Cable (CX-13313)	4-10
4.18	TACFIRE Magic Cable (CX-13402)	4-10
4.19	Splitter Cable (CX-13417)	4-11
4.20	Power Cable (CX-13450)	4-11
4.21	Digital Adapter Cable (CX-13465)	4-12
4.22	Audio/Data Cable (W4)	4-12
V	<u>SELECTED GRAPHICS</u>	
5.1	Mounting Base (MB) (MT-6352)	5-2
5.2	Vehicular Amplifier Adapter (VAA) (AM-7239 Series)	5-2
5.3	RF Power Amplifier (PA) AM-7238)	5-3
5.4	Receiver-Transmitter (RT) (RT-1523 Series)	5-3
5.5	Remote Control Unit (RCU) (C-11561)	5-4
5.6	Control-Monitor (CM) (C-11291)	5-4
5.7	Loudspeaker (LS) (LS-671)	5-5
5.8	Handset (HS) (H-250)	5-5
5.9	Short Range RT-A	5-6
5.10	Short Range RT-B	5-7
5.11	Long Range RT-A	5-8
5.12	Long Range RT-B	5-9
	<u>INDEX</u>	INDEX-1

THIS PAGE INTENTIONALLY BLANK.

SECTION I

INTRODUCTION

1.1 YOUR "UNIT MAINTENANCE HANDBOOK"

PURPOSE. Your "Unit Level Maintenance Handbook," TM 11-5820-890-20-3 (Short Title: TM 20-3), is designed for you, the unit level SINCGARS maintainer, to use in the field, inside combat vehicles, and in all kinds of weather. This handbook assumes that you are a trained SINCGARS maintainer and have ready access to TM 11-5820-890-20-1 and TM 11-5820-890-20-2 (Short Titles TM 20-1 and TM 20-2), "Unit Maintenance Manual," which contain detailed maintenance instructions. Your logbook size handbook contains abbreviated troubleshooting procedures, which when properly applied will provide the same results as the procedures contained in TM 20-1. Your handbook also offers selected technical data which you may use as guides or memory joggers. The basic purpose of this manual is to provide you essential job information that you can carry with you in the field. It is expected that you will refer to TM 20-1 and TM 20-2 whenever more detailed information is required.

BASIS OF ISSUE. This logbook size handbook is issued on the basis of one per unit level SINCGARS maintainer. You are encouraged to treat this guide as "personal property," adding notes and making changes as your experience warrants. It is intended that this manual be taken with you whenever you are required to work on SINCGARS radios in the field.

LOCATING SUBJECTS. Several features of this handbook make it easy for the unit maintainer to find desired material. There is a complete Table of Contents at the front of the manual, a detailed Subject Index at the rear. Also, Sections IV and V have Tables of Contents at the front of each section.

GOAL. The goal is to provide the unit maintainer adequate guidance to be able to troubleshoot, properly identify, and correct most problems encountered in the field for both manpack and vehicular radios. It does not replace or preclude the need to use TMs 20-1 and 20-2 when more specific, in-depth guidance is required for job performance.

HOW TO USE YOUR UNIT MAINTENANCE HANDBOOK. Use of TM 20-3 is illustrated in this example. A unit maintainer is called to a combat vehicle that has a radio problem. By questioning the radio operator, the maintainer determines the general nature of the problem. The unit maintainer then performs the appropriate Operational Check found in the Handbook, performing each step in the manner and the order prescribed. This procedure will take the maintainer to the point where the faulty component is identified, or the maintainer is referred to one or more specific troubleshooting guide to use. Once the faulty component has been identified and either replaced or repaired, the maintainer again performs the Operational Check to ensure that the entire system is in fact operational. Handbook chapters entitled Cable Schematics and Selected Graphics provide additional information which may be of use to the maintainer during the troubleshooting and replacement/repair effort. When the problem can be isolated to components other than the radio system (e.g. VIC-1, Control-Monitor, RCU, Single Radio Mount), the maintainer must use TM 20-2 rather than the handbook to continue troubleshooting.

1.2 SCOPE

This "Unit Level Maintenance Handbook, " TM 20-3 contains troubleshooting guides and selected technical data applicable to SINCGARS ICOM Ground Radios, AN/PRC-119A and AN/VRC-87A through AN/VRC-92A. Abbreviated Troubleshooting Guides (TSG) provide identical procedures to those found in TM 20-1. In general, these guides tell the maintainer "what" needs to be done, but not "how." Cable schematics and selected graphics offer the experienced unit maintainer additional information on which to troubleshoot and replace or repair faulty components.

1.3 AVOIDING "FALSE PULLS"

A "False Pull" is what occurs when a component or LRU is identified as faulty and sent to Direct Support Maintenance when in fact the item is operational. False Pulls hurt your unit in several ways. A piece of equipment has been needlessly removed from the unit, reducing mission readiness and operational capabilities. Also, replacing an operational component with a like item did nothing to correct the problem which started the maintenance action. And, importantly, the number of good components needlessly sent to DS for maintenance can reflect positively or negatively on your unit maintainers, as well as slowing down the repair process for actual failed components.

How can False Pulls be avoided? Recognizing the nature of electrical and electronic component failures, it may not be possible to avoid ever experiencing a False Pull. But, it is possible to avoid all but a few. Here is how. Follow some simple, straightforward rules:

- a. **Don't** guess; **DO** troubleshoot.
- b. **Don't** rely on memory; **DO** use your Handbook or TM.
- c. **Don't** chase symptoms; **DO** perform the Operational Check.
- d. **Don't** "pull and push;" **DO** replace/repair the component identified by the Operational Check or TSG.
- e. **Don't** send replaced item to DS without double-checking; **DO** test LRU again after replacement to verify that it is faulty.

1.4 MAINTENANCE FORMS, RECORDS, AND REPORTS

REPORTS OF MAINTENANCE AND UNSATISFACTORY EQUIPMENT. Department of the Army forms and procedures used for equipment maintenance will be those prescribed by DA Pam 738-750, as contained in Maintenance Management Update.

REPORTING OF ITEM AND PACKING DISCREPANCIES. Fill out and forward SF 364 (Report of Discrepancy [ROD]) as prescribed in AR 735-11-2/DLAR 4140.55/SECNAVINST 4355. 18/AFR 400-54/MCO 4430.3J.

TRANSPORTATION DISCREPANCY REPORT (TDR) (SF 361). Fill out and forward TDR (SF 361) as prescribed in AR 55-38/NAVSUPINST 461 0.33 C/AFR 75-18/MCO P4610.19/DLAR 4500.15.

1.5 REPORTING EQUIPMENT IMPROVEMENT RECOMMENDATIONS (EIR)

If your series of radio sets needs improvement, let us know. Send us an EIR. You, the user, are the only one who can tell us what you don't like about the design. Put your comments on an SF 368 (Product Quality Deficiency Report). Mail it to: US Army CECOM, ATTN: AMSEL-LC-ED-CFO, Fort Monmouth New Jersey 07703-5023. We will send you a reply.

1.6 REPORTING ERRORS AND RECOMMENDING IMPROVEMENTS

You can help improve this manual. If you find any mistakes or if you know of away to improve the procedures, please let us know. Mail your letter or DA form 2028-2 (forms located in the back of this handbook) to: US Army CECOM, ATTN: AMSEL-LC-LM-LT, Fort Monmouth New Jersey 07703-5007. We will reply direct to you.

1.7 SECURITY CLASSIFICATION AND MARKING

The ICOM SINCGARS ground combat net radio is designated as a Controlled Cryptographic Item (CCI). Handle in accordance with TB 380-41-5.

1.8 DESTRUCTION OF ARMY ELECTRONICS MATERIEL

Destruction of Army electronics materiel to prevent enemy use shall be in accordance with TM 750-244-2.

1.9 ABBREVIATIONS USED

ALOG	analog	N/A	nonapplicable
ANT	antenna	OP	operational
AUD	audio	PA	power amplifier
BTRY	battery	PSA	power supply adapter
CB	circuit breaker	PTT	push-to-talk
CCI	controlled cryptographic item	PTTest	push-to-test
CCW	counterclockwise	PAR	power
CDR	commander	R	receive
CHAN	channel	RCU	remote control unit
CM	control-monitor	RF	radio frequency
CNTL	control	ROD	report of discrepancy
COMSEC	communication security	RT	receiver-transmitter
CONN	connector	RVS	reverse
CT	ciphertext	RXMT	retransmit
CVC	combat vehicle crew	SC	single channel
CW	clockwise	SIG	signal
DIG	digital	SNAP steerable null antenna processor	
DRV	driver	SR	short range
ECCM	electronic counter counter-measure	SRM	single radio mount
EIR	equipment improvement report	T	transmit
EXT	external	TB	technical bulletin
FCTN	function	TDR .	transportation discrepancy report
FH	frequency-hopping	TS	troubleshooting
FREQ	frequency	TSG	troubleshooting guide
FSK	frequency shift keying	TST	test
FWD	forward	TM	technical manual
GD	good	UUT	unit under test
GND	ground	VAA	vehicular amplifier adapter
HS	handset	VAR	variable
HUB	hold-up battery	VEH	vehicle
ICOM	integrated COMSEC	VIC	vehicle intercom
JT	junction	VOL	volume
LR	long range	VRMS	volts root mean square
LS	loudspeaker	VSWR	voltage standing wave ratio
MHZ	megahertz	W	watts
MT	mount	Z	zero
MTG	mounting		

SECTION II

MANPACK RADIO

2.1. OPERATIONAL CHECK.

In using the Operational Check, it is important that you perform each step and sub-step exactly as stated and in the order presented. The Operational Check will tell you what specific action to take or will direct you to one of the TS Guides. After replacing or repairing the faulty component, you need to re-run the Operational Check, or at least perform a communication check, to ensure that the entire radio system under test is in fact then fully operational.

Step 1. PREPARATION

STEPS	CHECKS	ACTIONS
1.1 Set RT: FCTN to OFF CHAN to 1 MODE to SC RF PWR to HI VOL to Mid-Range DIM to Full CW COMSEC to Z	N/A N/A N/A N/A N/A N/A N/A	N/A N/A N/A N/A N/A N/A N/A
1.2 Handset, H-250 (HS) : Connect to RT AUD/DATA	Ensure HS is operational	Install known good HS
1.3 Main Battery: Ensure good power	Ensure good power	Install known good battery
1.4 Hold-Up Battery (HUB) : Ensure good HUB	Ensure good HUB	Install known good HUB

Step 2. POWER CHECKS

STEPS	CHECKS	ACTIONS
2.1 Set RT FCTN to Z-FH	RT display lights?	YES: Go to Step 2.2 NO: Replace Battery Box*
	RT display then lights?	YES: Go to Step 2.2 NO: Replace RT
2.2 Set RT FCTN to OFF, return to Z-FH, and observe RT display	RT display reads GOOD?	YES: Continue NO: Replace RT
	RT HUB lit?	NO Go to STEP 3 YES.: Replace HUB*
	RT HUB still lit?	NO: Go to STEP 3 YES: Replace RT

* After completing a corrective action, continue with next Operational Check step.

2.1. OPERATIONAL CHECK. Continued

Step 3. RT SELF-TEST

STEPS	CHECKS	ACTIONS
3.1 Set RT COMSEC to CT Set RT FCTN to TST	N/A RT passes self-test?	N/A YES: Go to Step 3.2 NO: Disconnect ANT and HS; rerun self-test
	RT then passes self-test?	YES: Connect ANT and HS; go to Step 3,2 NO: Replace RT
3.2 Set RT: FCTN to LD CHAN to MAN DATA to OFF	N/A N/A RT display reads 30000?	N/A N/A YES: Continue NO: Replace RT
	COMSEC alarm sounds?	YES: Go to Step 3,3 NO: Replace RT
3.3 Press PTT twice	COMSEC alarm clears?	YES: Go to STEP 4 NO: Replace RT

Step 4. LOAD CHECKS

STEPS	CHECKS	ACTIONS
4.1 Load RT: Chan 1: 41000 Chan 2: 54000 Chan 3: 75000	SC frequencies load properly?	YES: Go to Step 4.2 NO: Replace RT
4.2 Load COMSEC and FH data*	RT accepts fill?	YES: Go to Step 4.3 NO: Go to TS Guide 1
4.3 Load test sync time (82/09:36)	Test sync time loads properly?	YES: Go to Step 4.4 NO: Replace RT
4.4 Set RT to STBY	RT shuts down properly?	YES: Go to Step 4.5 NO: Replace RT
4.5 Remove Main Btry Replace after 1 min. Set RT FCTN to SQ ON	RT retains data in FH and SC?	YES: Go to Step 4.6 NO: Replace RT
4.6 Set RT FCTN to LD Load Btry Life Condition	N/A Btry Life loads?	N/A YES: Go to STEP 5 NO: Replace RT

* If using an ANCD, follow ICOM Fill procedure to load COMSEC keys and FH data in all 6 channels. Otherwise, load COMSEC keys and FH data in Channels 1, 2, and 3.

2.1. OPERATIONAL CHECK. Continued

Step 5. TRANSMITTER CHECKS

STEPS	CHECKS	ACTIONS
5.1 Remove antenna from RT Connect RF cable from test set RADIO to RT ANT Connect test set ANT to dummy load Set test set MODE to FWD PWR Set RT: FCTN . to SQ ON CHAN to 1 MODE to SC RF PWR to HI	N/A N/A N/A N/A N/A N/A N/A N/A	N/A N/A (See Typical SC Test Setup diagram following) N/A N/A N/A N/A N/A N/A
5.2 Press PTT and test set PTTTest	Test set reads 2 W or greater?	YES: Go to Step 5.3 NO: Go to TS Guide 2
5.3 Press PTT	SIG display reads 4 or more?	YES: Go to Step 5.4 NO: Replace RT
5.4 Repeat above check for CHAN 2	SIG display reads 4 or more?	YES: Go to Step 5.5 NO: Replace RT
5.5 Repeat above check for CHAN 3	SIG display reads 4 or more?	YES: Go to Step 5.6 NO: Replace RT
5.6 Set RT CHAN to 1 Press PTT, count into HS	N/A Sidetone heard?	N/A YES: Go to Step 5.7 NO: Replace RT
5.7 Set test set MODE to FREQ Press PTT and PTTTest	Test set reads 40998 to 41002?	YES: Go to Step 5.8 NO: Replace RT
5.8 Set RT CHAN to 2 Press PTT and PTTTest	N/A Test set reads 53998 to 54002?	N/A YES: Go to Step 5.9 NO: Replace RT
5.9 Set RT CHAN to 3 Press PTT and PTTTest	N/A Test set reads 74998 to 75002?	N/A YES: Go to Step 5.10 NO: Replace RT
5.10 Set RT FCTN to RXMT Connect HS to RT RXMT Listen at HS	N/A N/A Rushing noise heard?	N/A N/A YES: Go to Step 5.11 NO: Replace RT
5.11 Press PTT	RT SIG display reads 4 or more?	YES: Go to Step 5.12 NO: Replace RT
5.12 Set RT FCTN! to SQ ON Connect HS to RT AUD/DATA Remove RF cable from RT ANT Connect antenna to RT ANT Press PTT, count into HS*	N/A N/A N/A N/A Sidetone heard in HS?	N/A N/A N/A N/A YES: Go to STEP 6 NO: Go to TS Guide 3

* If unit SOP or tactical situation prohibits transmitting, use dummy load and realize that antenna cannot be checked.

2.1. OPERATIONAL CHECK. Continued

TYPICAL SC TEST SETUP

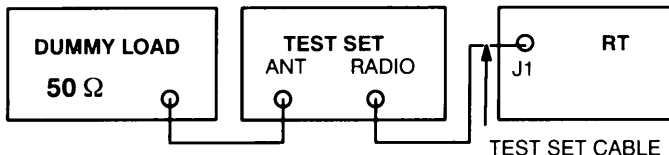

Step 6. RECEIVER CHECKS

STEPS	CHECKS	ACTIONS
6.1 Remove antenna from RT ANT Connect RF cable from test set RADIO to RT ANT Remove cable from test set ANT Set test set MODE to SENS SQ Set RT: CHAN to 3 COMSEC to PT FCTN to SQ ON	N/A N/A N/A N/A N/A N/A N/A	N/A N/A N/A N/A N/A N/A N/A
6.2 Press PTTTest	Test tone heard in HS?	YES: End of Operational Check NO: Replace RT

(End of Manpack Radio Operational Check; See TS Guide 4 for check if having trouble with transmitting/ receiving data using data device.)

2.2. TROUBLESHOOTING GUIDES.

TS Guide 1. VARIABLE WILL NOT LOAD

STEPS	CHECKS	ACTIONS
1.1 Replace fill cable with good one and load a variable	Variable loads?	NO: Go to 1.2 YES: Replaced fill cable is bad
1.2 Replace device btry with good one and load a variable	Variable loads?	NO: Go to 1.3 YES: Replaced btry is bad
1.3 Replace fill device with good one and load a variable	Variable loads?	YES: Replaced fill device is bad NO: Replace RT

TS Guide 2. LOW OR NO POWER OUT

STEPS	CHECKS	ACTIONS
2.1 Note color of RT ANT J1	RT ANT J1 Silver-colored?	YES: Go to 2.2 NO: Replace RT
2.2 Remove test set cable from RT ANT Visually Inspect RT ANT J1	Damaged RT ANT J1 ?	NO: Go to 2.3 YES: Replace RT ANT J1
2.3 Set RT FCTN to LD Place red probe on center of ANT J1 Place black probe on outside of J1 Read DMM while pressing center conductor of J1 in, with red probe	N/A N/A N/A Resistance drops more than 2 Ohms?	N/A N/A Read DMM YES: Replace RT NO: Replace RT ANT J1

2.2. TROUBLESHOOTING GUIDES. Continued

TS Guide 3. LOSS OF SIDETONE

STEPS	CHECKS	ACTIONS
3.1 Replace manpack antenna * Press PTT and count into HS **	N/A Sidetone heard?	N/A YES: Go to 3.2 NO: Go to 3.3
3.2 Remove antenna Install original antenna base Install new antenna element on base Press PTT and count into HS	N/A N/A N/A Sidetone heard?	N/A N/A N/A YES: Replaced antenna elements are bad NO: Replace antenna base
3.3 Note color of RT ANT J1	Silver-colored?	YES: Go to 3.4 NO: Replace RT
3.4 Note type of antenna used	AS-4266 antenna used?	NO: Go to 3.5 YES: Replace RT
3.5 Remove antenna Set RT FCTN to LD Place red probe on center conductor of RT ANT J1 *** Place black probe on outside of RT ANT J1 Read DMM	N/A N/A N/A N/A 5.0 to 6.5 Ohms?	N/A N/A N/A N/A YES: Replace RT NO: Replace RT ANT J1

- * Replace antenna with same model as antenna removed.
- ** Use the same frequency where loss of sidetone occurred.
- *** **DO NOT** depress center connector.

TS Guide 4. RADIO WILL NOT OPERATE WITH DATA DEVICES

STEPS	CHECKS	ACTIONS
4.1 Run Op Check on RT	Op Check failed?	NO: Go to 4.2 YES: Replace RT
4.2 Run Self-Test/Op Check on data device	Self-Test/Op Check failed?	NO: Go to 4.3 YES: Replace data device
4.3 Test interface cable for opens and shorts	Cable open or shorted?	NO: Go to 4.4 YES: Replace cable
4.4 Replace data device with known good data device * Operate system**	N/A System operates?	N/A YES: Replaced data device is bad NO: Replace RT

- * If a data device is not available, replace the RT. If the system then operates, the replaced RT is bad.
- ** Skip this step if the tactical situation or your unit SOP precludes transmitting.

SECTION III

VEHICULAR RADIOS

3.1. OPERATIONAL CHECK.

IMPORTANT POINTS TO REMEMBER IN USING THE OPERATIONAL CHECK

Ž When an Operational Check step involves an item of equipment which is not used in the system being checked, merely skip that step and continue to the next step.

- It is important that Operational Check steps be performed as stated and in the order presented.
- If a VIC is used with the UUT, determine as early as possible whether the problem is in the VIC or the radio; then troubleshoot that part of the system. (Refer to Chapter 2, TM 20-2, for details)
- When the Operational Check is complete, make a communications check (unless prohibited) and repeat the Operational Check to ensure the system is completely operational,
- When removing or installing components, ensure VAA CB1 is in the OFF position.
- Do not accept power outputs less than those specified.
- Before beginning an Operational Check on any vehicular radio system, verify good power with engine running and engine off, Obtain assistance of unit vehicle mechanic as required.

Step 1. PREPARATION

STEPS	CHECKS	ACTIONS
1.1 Set RT: FCTN . to OFF CHAN to 1 MODE to SC RF PWR to HI VOL to Mid-Range DIM to Full CW COMSEC to Z	N/A N/A N/A N/A N/A N/A N/A	N/A N/A N/A N/A N/A N/A N/A
1.2 Set VAA CB1 to OFF DS1 to Full CCW If LS-671 or VIC is used: If neither is used:	N/A N/A Ensure VAA is set to REMOTE. Ensure VAA is set to LOCAL.	N/A N/A Set VAA to REMOTE Set VAA to LOCAL
1.3 Set all LS-671: CB1 to OFF DS1 to Full CCW VOL to OUT/Mid-Range	N/A N/A N/A	N/A N/A N/A
1.4 Set PA Mount: CB1 to OFF DS1 to Full CCW	N/A N/A	N/A N/A
1.5 Handset (HS), H-250: Connect to VAA J3 (RT-A)/J2 (RT-B)	Ensure HS is operational and dis- connect all other handsets. N/A	Install known good HS N/A

3.1. OPERATIONAL CHECK. Continued

Step 2. POWER CHECKS

STEPS	CHECKS	ACTIONS
2.1 Set VAA CB1 to ON Set RT-A LS-671 to ON	VAA CB1 trips?*	NO: Continue ↓ YES: Go to TS Guide 1
	VAA DS1 lights?	YES: Continue ↓ NO: Go to TS Guide 2
	VAA DS1 blinks continuously?	NO: Continue ↓ YES: Replace VAA
	LS-671 CB1 trips?	NO: Continue ↓ YES: Replace LS-671
	LS-671 DS1 lights?	YES: Go to Step 2.2 NO: Go to TS Guide 3
2.2 Set RT- B LS-671 to ON and RT-A LS-671 to OFF	LS-671 CB1 trips?	NO: Continue ↓ YES: Replace LS-671
	LS-671 DS1 LIGHT	YES: Set RT-A LS-671 -ON and go to Step 2.3 NO: Go to TS Guide 4
2.3 Set RT-A LS-671 to ON Set PA Mount CB1 to ON	PA Mount CB1 trips?	NO: Continue ↓ YES: Go to TS Guide 5
	PA Mount DS1 Lights?	YES: Go to Step 2.4 NO: Go to TS Guide 6
2.4 Set RT FCTN to Z-FH	RT display lights?	YES: Go to Step 2.5 NO: Go to TS Guide 7
2.5 Set RT FCTN to OFF return FCTN to Z-FH, and observe RT display	RT display reads GOOD?	YES: Continue ↓ NO: Replace RT if it reads other than GOOD
	RT HUB lit?	NO: Go to STEP 3 YES: Replace HUB
	RT HUB still lit?	NO: Go to STEP 3 YES: Replace RT

* If VAA CB1 still trips after completing a TS Guide 1 corrective action, go back to TS Guide 1 and continue.

3.1. OPERATIONAL CHECK. Continued

Step 3. RT SELF-TEST

STEPS	CHECKS	ACTIONS
3.1 Set RT: COMSEC to CT FCTN to TST	N/A RT display reads FAIL 6?	N/A NO: Continue ↓ YES: Go to TS Guide 8
	RT passes self-test?	YES: Go to Step 3.2 NO: Remove cables/HS; rerun self-test
	RT then passes self-test?	YES: Connect cables/HS; NO: Replace RT
3.2 Set RT: FCTN to LD CHAN to MAN DATA to OFF	N/A N/A RT display reads 30000?	N/A N/A YES: Continue ↓ NO: Replace RT
	COMSEC alarm heard at HS/loudspeaker?	YES: Go to Step 3.3 NO: If no external devices are used,* go to TS Guide 9; NO: If <u>using</u> external devices,* go to TS Guide 10
3.3 Press PTT twice	COMSEC alarm clears?	YES: Go to STEP 4 NO: If no external devices are used, * go to TS Guide 9; NO: If <u>using</u> external devices,* go to TS Guide 10

* For example, LS-671, LS-454, VIC.

3.1. OPERATIONAL CHECK. Continued

Step 4. LOAD CHECKS

STEPS	CHECKS	ACTIONS
4.1 Load RT: Chan 1: 41000 Chan 2: 54000 Chan 3: 75000	SC frequencies load properly?	YES: Go to Step 4.2 NO: Replace RT
4.2 Set RT MODE to FH and load COMSEC and FH data*	RT accepts fill?	YES: Go to Step 4.3 NO: Go to TS Guide 11
4.3 Load test sync time (82/09:36)	I Test sync time loads properly?	I YES: Go to Step 4.4 NO: Replace RT.
4.4 Set RT to STBY	RT shuts down properly?	I YES: Go to Step 4.5 NO: Replace RT
4.5 Set CB1 to OFF, wait 1 min., and set CB1 to ON Set FCTN to SQ ON	N/A RT retains COMSEC, FH, and SC data in FH and SC modes?	N/A YES: Go to STEP 5 NO: Replace RT

* NOTE: If using an Automated Net Control Device (ANCD), follow ICOM Fill procedure to load COMSEC and FH data in all 6 channels. Otherwise, load COMSEC keys and FH data in Channels 1,2, and 3.

3.1. OPERATIONAL CHECK. Continued

Step 5. TRANSMITTER CHECKS *

STEPS	CHECKS	ACTIONS
5.1 Remove RF cable from RT ANT Connect test set cable from test set RADIO to RT ANT. Connect vehicular antenna cable to test set ANT Set test set: MODE to FWD PWR Set RT: FCTN to SQ ON CHAN to 1 MODE to SC COMSEC to CT	N/A N/A N/A N/A N/A N/A N/A N/A	N/A N/A N/A (See following SC Test Setup diagram.) N/A N/A N/A N/A
5.2 Press PTT and PTTest	Test set FWD PWR reads 2-6 W?	YES: Go to Step 5.3 NO: Go to TS Guide 12
5.3 Set test set MODE to RVS PWR Press PTT and PTTest	Test set reads no more than 1/3** of FWD PWR?	YES: Go to Step 5.4 NO: Go to TS Guide 12
5.4 Press PTT	RT SIG display reads 4 or more?	YES: Go to Step 5.5 NO: Replace RT
5.5 Set RT CHAN to 2 Repeat Steps 5.2 & 5.3	Test set reads no more than 1/3** of FWD PWR?	YES: Go to Step 5.6 NO: Go to TS Guide 12
5.6 Set RT CHAN to 3 Repeat Steps 5.2 & 5.3	Test set reads no more than 1/3** of FWD PWR?	YES: Go to Step 5.7 NO: Go to TS Guide 12
5.7 Set RT CHAN to 1 Press PTT, count into HS	Sidetone heard?	YES: Go to Step 5.8 NO: Got to TS Guide 13
5.8 Set test set MODE to FREQ Press PTT and PTTest	Test set reads 40998 - 41002?	YES: Go to Step 5.9 NO: Replace RT
5.9 Set RT CHAN to 2 Press PTT and PTTest	Test set reads: 53998 - 54002?	YES: Go to Step 5.10 NO: Replace RT
5.10 Set RT CHAN to 3 Press PTT and PTTest	Test set reads: 74998 - 75002?	YES: Go to Step 5.11 NO: Replace RT
5.11 Set RT FCTN to RXMT Connect HS to RT RXMT Listen at HS	N/A N/A Rushing noise heard at HS?	YES: Go to Step 5.12 NO: Replace RT
5.12 Press PTT	SIG display reads 4 or more?	YES: Go to STEP 6 NO: Replace RT

* Skip this step if the tactical situation or your unit SOP precludes transmitting. If unit SOP or tactical situation prohibits transmitting, use dummy load and realize that antenna cannot be checked.

** If radio is used for data transmission, use 1/4 rather than 1/3 for these checks.

3.1. OPERATIONAL CHECK. Continued

TYPICAL SC TEST SETUP:

SHORT RANGE RADIOS

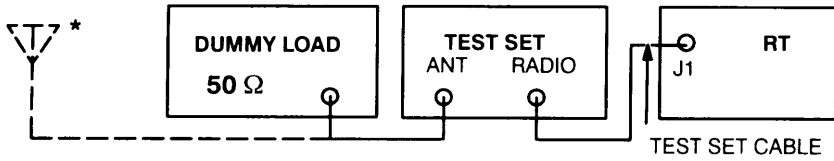

* INDICATES ANTENNA DISCONNECTED

LONG RANGE RADIOS

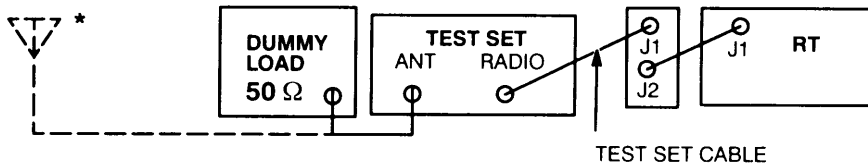

* INDICATES ANTENNA DISCONNECTED

Step 6. RECEIVER CHECKS

STEPS	CHECKS	ACTIONS
6.1 Remove vehicular antenna cable from test set ANT Set test set: MODE to SENS SQ Set RT: COMSEC to PT CHAN to 3	N/A N/A N/A N/A	N/A N/A N/A N/A
6.2 Press PTTTest	Test tone heard in HS?	YES: Go to Step 6.3 NO: Replace RT
6.3 Connect HS to RT AUD/FILL Set RT FCTN to SQ ON Press PTTTest	N/A N/A Test tone heard in HS?	N/A N/A YES: Go to STEP 7 NO: Replace RT

3.1. OPERATIONAL CHECK. Continued

Step 7. POWER AMPLIFIER CHECKS *

STEPS	CHECKS	ACTIONS
7.1 Connect vehicular antenna cable to test set ANT Connect W2 cable to RT ANT and PA J2 Set test set: MODE to FWD PWR Connect test set cable from test set RADIO to PA J1 Set RT CHAN to 1	N/A N/A N/A N/A N/A	N/A N/A N/A N/A N/A
7.2 Press PTT and PTTTest	Test set reads 2W or greater?	YES: Go to Step 7.3 NO: Go to TS Guide 14
7.3 Set RT RF PWR to PA Press PTT and PTTTest	N/A Test set reads 30 W or greater?	N/A YES: Go to Step 7.4 NO: RT-A; Go to TS Guide 15 RT- B; Go to TS Guide 16
7.4 Set RT CHAN to 2 Press PTT and PTTTest	N/A Test set reads 30 W or greater?	N/A YES: Go to Step 7.5 NO: RT-A; Go to TS Guide 17 RT- B; Go to TS Guide 18
7.5 Set RT CHAN to 3 Press PTT and PTTTest	N/A Test set reads 30 W or greater?	N/A YES: Go to Step 7.6 NO: RT-A; Go to TS Guide 17 RT- B; Go to TS Guide 18
7.6 Press PTT and count into HS	Sidetone heard at HS?	YES: Continue ↓ NO: Replace PA
	RT SIG display reads 6 or 7?	YES: Go to STEP 8 NO: Go to TS Guide 19

* If unit SOP or tactical situation prohibits transmitting, use dummy load and realize that antenna cannot be checked.

3.1. OPERATIONAL CHECK. Continued

Step 8. LS-671 CHECKS

STEPS	CHECKS	ACTIONS
8.1 Set test set: MODE to FWD PWR Connect HS to LS-671 J2 Push LS-671 volume IN Set RT: COMSEC to CT FCTN to TST MODE to SC RF PWR to HI	N/A N/A N/A N/A N/A N/A N/A	N/A N/A N/A N/A N/A N/A
8.2 Check for beeps	Beeps heard at HS only?	YES: Go to Step 8.3 NO: Replace LS-671
8.3 Set RT: COMSEC to PT FCTN to SQ ON Press PTT	N/A N/A RT SIG display reads 4 or more?	N/A N/A YES: Go to Step 8.4 NO: Go to TS Guide 20
8.4 Pull LS-671 volume OUT Press PTT and count into HS	N/A Sidetone heard at HS?	N/A YES: Continue ↓ NO: Go to TS Guide 21
	Sidetone heard at LS-671 ?	YES: Replace LS-671 NO: End of Operational Check*

* Return HS to operational position, if required. Repeat step 8 if second LS-671 is used

(End of Vehicular Radio Operational Check; See TS Guide 22 for check if having trouble with transmitting /receiving data using data device.)

3.2. TROUBLESHOOTING GUIDES.

TS Guide 1. VAA CB1 TRIPS WHEN SET TO ON

* Read notes below before troubleshooting

STEPS	CHECKS	ACTIONS
1.1 Remove cables from MB J2/J3/J4 and VAA J9 Set VAA to LOCAL Set VAA CB1 to ON	N/A N/A CB1 trips?	N/A N/A YES: Go to 1.10 NO: Go to 1.2
1.2 Check external equipment	VIC used?	YES: Go to 1.3 NO: Go to 1.4
1.3 Remove CX-13300 from VIC Check continuity at CX-13300, Pin C to Pin A (GND)	N/A Short to GND?	N/A YES: Replace CX-13300 ** NO: Problem is with VIC
1.4 Check external equipment	C-M used?	YES: Go to 1.5 NO: Go to 1.6
1.5 Remove CX-13290 from C-M Check continuity at CX-13290, Pin F to Pin A (GND)	N/A Short to GND?	N/A YES: Replace CX-13290 ** NO: Problem is with C-M
1.6 Check external equipment	LS-671 used?	YES: Go to 1.7 NO: Go to 1.8
1.7 Remove CX-13292 from LS-671 J1 Check continuity at LS-671 J1 , Pin C to Pin A (GND)	N/A Short to GND?	N/A YES: Replace LS-671 ** NO: Replace CX-13292
1.8 Check external equipment	RT- B PA Mount used?	YES: Go to 1.9 NO: Go to 1.10
1.9 Remove PA from PA Mount Remove CX-13303 from PA Mount J1 Check continuity at PA Mount J1, Pin C to Pin A (GND)	N/A N/A Short to GND?	N/A N/A NO: Replace CX-13303** YES: Replace PA Mount
1.10 Remove VAA from MB Check continuity at MB J5, Pin C to Pin A (GND)	N/A Short to GND?	N/A NO: Replace VAA YES: Replace MB

* NOTES:

- (1) If a second radio is "daisy chained" to J2, disconnect cable at J2, If problem clears , reconnect and re-run Op Check on second radio set.
- (2) If UUT is an AN/VRC-89A/90A/91A/92A, RT-A PA can trip the circuit breaker. Remove PA, set CB1 to ON, and try again. If problem clears, RT-A PA is bad.
- (3) If UUT has LS-671 (s), set VAA to LOCAL, remove all cables from MB J3/J4, and set CB1 to ON. If problem clears, go to Step 1.5.
- (4) If UUT has RT-B PA Mount, disconnect cable from J2. If problem clears, go to Step 1.6,
- ** (5) After completing a corrective action, continue with the next Operational Check step.

3.2. TROUBLESHOOTING GUIDES. Continued

TS Guide 2. VAA DS1 NOT LIT WHEN CB1 IS SET TO ON

STEPS	CHECKS	ACTIONS
2.1 Set RT FCTN to SQ ON	RT display lit?	NO: Go to 2.2 YES: Replace VAA DS1
2.2 Set RT FCTN to OFF Turn VAA & LS-671 CB1s to OFF Check power source	N/A N/A 22-32 Vdc?	N/A N/A YES: Go to 2.3 NO: Veh btry/power is bad
2.3 Remove VAA from MB Remove power cable from MB J1 Measure voltage at power cable, Pin B to Pin A (GND)	N/A N/A 22-32 Vdc?	N/A N/A YES: Go to 2.4 NO: Replace power cable
2.4 Reconnect power cable to MB J1 Measure voltage at MB J5, Pin B to Pin A (GND)	N/A 22-32 Vdc?	N/A YES: Continue ↓ NO: Replace MB
	AM-7239* used?	NO: Continue ↓ YES: Replace VAA
	LS-671 used?	YES: Go to 2.5 NO: Replace VAA
2.5 Remove CX-13292 from MB J3 Set VAA to LOCAL and install Set VAA CB1 to ON	N/A N/A DS1 lit?	N/A N/A YES: Go to 2.6 NO: Replace VAA
2.6 Set RT-A LS-671 CB1 to ON Check continuity at CX-13292, Pin B to Pin D	N/A Open?	N/A YES: Go to 2.7 NO: Go to 2.8
2.7 Remove CX-13292 at RT-A LS-671 J1 Check continuity at LS-671 J1, Pin B to Pin D	N/A Open?	N/A YES: Replace LS-671 NO: Replace CX-13292
2.8 Set VAA & RT-A LS-671 CB1s to OFF Remove VAA Measure voltage at MB J3, Pin B to Pin A (GND)	N/A N/A 22-32 Vdc?	N/A N/A YES: Go to 2.9 NO: Replace MB
2.9 Check continuity at MB J5, Pin E to J3, Pin D	Open?	YES: Replace MB NO: Go to 2.10
2.10 Reconnect CX-13292 at MB J3 Set VAA to REMOTE and install Set VAA & RT-A LS-671 CB1s to ON	N/A N/A DS1 lit?	N/A N/A YES: Problem was loose cable or improperly seated equipment Replace VAA NO: Replace VAA

* Not AM-7239A or AM-7239B

3.2. TROUBLESHOOTING GUIDES. Continued

TS Guide 3. RT-A LS-671 DS1 NOT LIT AND VAA DS1 IS LIT

STEPS	CHECKS	ACTIONS
3.1 Replace RT-A LS-671 DS1	DS1 lit?	NO: Continue ↓ YES: Replaced DS1 is bad
	AM-7239 * used?	YES: Go to 3.2 NO: Go to 3.3
3.2 Set RT FCTN to SQ ON	RT display lit?	YES: Go to 3.3 NO: Go to 3.6
3.3 Set RT FCTN to OFF Set VAA & RT-A LS-671 CB1s to OFF Check continuity at VAA P1, Pin C to J9, Pin F	N/A N/A Open?	N/A N/A NO: Go to 3.4 YES: Replace VAA
3.4 Remove CX-13292 from MB J3 Check continuity at MB J3, Pin C to J5, Pin C	N/A Open?	N/A NO: Go to 3.5 YES: Replace MB
3.5 Remove CX-13292 from LS-671 J1 Set LS-671 CB1 to ON Measure resistance at LS-671 J1, Pin C to Pin A (GND)	N/A N/A Greater than 20 K Ohms?	N/A N/A YES: Go to 3.9 NO: Replace LS-671
3.6 Set RT FCTN to OFF Set VAA & LS-671 CB1s to OFF Remove CX-13292 from RT-A LS-671 J1 Set RT-A LS-671 CB1 to ON Check continuity at LS-671 J1, Pin B to Pin D	N/A N/A N/A N/A Open?	N/A N/A N/A N/A NO: Go to 3.7 YES: Replace LS-671
3.7 Set RT-A LS-671 CB1 to OFF Reconnect CX-13292 to LS-671 J1 Remove VAA from MB Set RT-A LS-671 CB1 to ON Measure voltage at MB J5, Pin E to Pin A (GND)	N/A N/A N/A N/A 22-32 Vdc?	N/A N/A N/A N/A NO: Go to 3.8 YES: Replace VAA
3.8 Remove CX-13292 from MB J3 Check continuity at CX-13292, Pin B to Pin D	N/A Open?	N/A YES: Replace CX-13292 NO: Replace MB
3.9 Connect CX-13292 to LS-671 J1 Measure resistance at CX-13292, Pin C to Pin A (GND)	N/A Greater than 20 K Ohms?	N/A YES: Replace LS-671 NO: Replace CX-13292

* Not AM-7239A or AM-7239B

3.2. TROUBLESHOOTING GUIDES. Continued

TS Guide 4. NO REMOTE POWER FROM RT-B LS-671

STEPS	CHECKS	ACTIONS
4.1 Turn LS-671 DS1 full CCW Turn LS-671 CB1 to ON	N/A VAA DS1 lit?	N/A NO: Go to 4.2 YES: Go to 4.4
4.2 Set VAA & RT-B LS-671 CB1s to OFF Remove VAA from MB Remove CX-13292 from MB J4 Set RT-B LS-671 CB1 to ON Check continuity at CX-13292, Pin B to Pin D	N/A N/A N/A N/A Open?	N/A N/A N/A N/A YES: Go to 4.3 NO: Replace MB
4.3 Remove CX-13292 from RT-B LS-671 J1 Check continuity at LS-671 J1, Pin B to Pin D	N/A Open?	N/A YES: Replace LS-671 NO: Replace CX-13292
4.4 Replace RT-B LS-671 DS1	LS-671 DS1 lit?	YES: Replaced DS1 is bad NO: Go to 4.5
4.5 Set VAA & RT-B LS-671 CB1 s to OFF Remove VAA from MB Remove CX-13292 from MB J4 Check continuity at MB J4, Pin C to J5, Pin C	N/A N/A N/A Open?	N/A N/A N/A NO: Go to 4.6 YES: Replace MB
4.6 Remove CX-13292 from LS-671 J1 Set LS-671 CB1 to ON Measure resistance at LS-671 J1, Pin C to Pin A (GND)	N/A N/A Greater than 20 K Ohms?	N/A N/A YES: Go to 4.7 NO: Replace LS-671
4.7 Connect CX-13292 to LS-671 J1 Measure resistance at CX-13292, pin C to Pin A (GND)	N/A Greater than 20 K Ohms?	N/A NO: Replace CX-13292 YES: Replace LS-671

TS Guide 5. PA MOUNT CB1 TRIPS AND VAA DS1 IS LIT

STEPS	CHECKS	ACTIONS
5.1 Remove PA	N/A	N/A
5.2 Set PA Mount CB1 to ON	CB1 trips?	NO: Replace PA YES: Replace PA Mount

3.2. TROUBLESHOOTING GUIDES. Continued

TS Guide 6. PA MOUNT DS1 NOT LIT AND VAA DS1 IS LIT

STEPS	CHECKS	ACTIONS
6.1 Replace PA Mount DS1	DS1 lit?	NO: Go to 6.2 YES: Replaced DS1 is bad
6.2 Remove PA from PA Mount Remove cable from PA Mount J1 Measure voltage at cable, Pin C to Pin A	N/A N/A 22-32 Vdc?	N/A N/A YES: Go to 6.3 NO: Go to 6.5
6.3 Measure voltage at cable, Pin B to Pin A	22-32 Vdc?	NO: Go to 6.4 YES: Replace PA Mount
6.4 Remove VAA from MB Remove power cable from MB J2 Measure voltage at MB J2, Pin B to Pin A (GND)	N/A N/A 22-32 Vdc?	N/A N/A YES: Replace CX-13303 NO: Replace MB
6.5 Remove VAA from MB Remove cables from MB J1 and J2 Check continuity at MB J2, Pin C to J5, Pin C	N/A N/A Open?	N/A N/A NO: Go to 6.6 YES: Replace MB
6.6 Check for external devices	LS-671 or VIC used?	NO: Go to 6.7 YES: Replace CX-13303
6.7 Ensure VAA is set to LOCAL Set CB1 to ON Check continuity at VAA P1, Pin C to J9, Pin F	N/A N/A Open?	N/A N/A YES: Replace VAA NO: Replace CX-13291

TS Guide 7. RT DISPLAY DOES NOT LIGHT AND VAA DS1 IS LIT

STEPS	CHECKS	ACTIONS
7.1 If no LS-671/VIC used, ensure VAA set to LOCAL Set RT FCTN to STBY Move RT-A/RT-B to other RT position Set RT FCTN to SQ ON Observe RT display	N/A N/A N/A N/A RT display lit?	N/A N/A N/A NO: Go to 7.2 YES: Replace VAA
7.2 Check AM-7239 model used	AM-7239B used?	NO: Go to 7.3 YES: Replace RT
7.3 Measure voltage at VAA J8/J7 (RT-A/B), Pin F to Pin Z (GND)	12.5-1 3.5 Vdc?	YES: Replace RT NO: Replace VAA

3.2. TROUBLESHOOTING GUIDES. Continued

TS Guide 8. RT DISPLAY READS FAIL 6

STEPS	CHECKS	ACTIONS
8.1 Replace RT with known good RT Set RT COMSEC to CT	N/A N/A	N/A N/A
8.2 Set RT FCTN to TST	Display reads FAIL 6?	NO: Replaced RT is bad YES: Replace VAA

**TS Guide 9. COMSEC ALARM NOT HEARD AT HS, OR WILL NOT CLEAR
(NO EXTERNAL DEVICE)**

STEPS	CHECKS	ACTIONS
9.1 Define problem	Alarm heard?	NO: Go to 9.2 YES: Go to 9.5
9.2 Connect HS to RT AUD/FILL	Alarm heard at HS?	YES: Go to 9.3 NO: Replace RT
9.3 Remove W4 from RT AUD/DATA Connect HS to RT AUD/DATA	N/A Alarm still heard?	N/A YES: Go to 9.4 NO: Replace RT
9.4 Check continuity at W4, Pin B to Pin B	Open?	YES: Replace W4 cable NO: Replace VAA
9.5 Remove W4 from RT AUD/DATA Connect HS to RT AUD/FILL Press PTT twice	N/A N/A Alarm clears?	N/A N/A YES: Go to 9.6 NO: Go to 9.9
9.6 Set RT FCTN to STBY then back to LD Connect HS to RT AUD/DATA Press PTT twice	N/A N/A Alarm clears?	N/A N/A YES: Go to 9.7 NO: Replace RT
9.7 Remove W4 from VAA Check continuity at W4 P1, Pin C to P2, Pin C	N/A Open?	N/A NO: Go to 9.8 YES: Replace W4 cable
9.8 Remove VAA from MB Check continuity at MB J3/J4, Pin to Pin A (GND)	N/A Short?	N/A YES: Replace MB NO: Replace VAA
9.9 Set RT FCTN to STBY, then back to LD Press PTT twice	N/A Alarm clears?	N/A NO: Go to 9.10 YES: Go to 9.6
9.10 Set RT FCTN to OFF, then back to LD Press PTT twice	N/A Alarm clears?	N/A YES: Go to 9.6 NO: Replace RT

3.2. TROUBLESHOOTING GUIDES. Continued

**TS Guide 10. COMSEC ALARM NOT HEARD, OR WILL NOT CLEAR
(EXTERNAL DEVICE)**

STEPS	CHECKS	ACTIONS
10.1 Define problem	Alarm heard?	Go to 10.2
	Alarm will not clear?	Go to 10.10
10.2 Check external devices	CX-13313 or CX-13417 present?	YES: Go to 10.3 NO: Go to 10.4
10.3 Remove VAA and set to LOCAL Remove cables from MB J3/J4 Reinstall VAA and RT Set RT: COMSEC to CT FCTN to LD	N/A N/A N/A N/A Alarm still heard?	N/A N/A N/A N/A NO: Go to TS Guide 9 YES: VIC/cables are bad
10.4 Recheck alarm	Alarm heard at HS?	YES: Go to 10.5 NO: Go to TS Guide 9
10.5 Check for LS-671 use	LS-671 present?	YES: Go to 10.6 NO: Go to 10.8
10.6 Recheck alarm	Alarm heard at LS-671 ?	NO: Go to 10.7 YES: Go to 10.8
10.7 Remove CX-13292 from LS-671 Set VAA to LOCAL Measure voltage at CX-13292, Pin K to Pin A	N/A N/A 0.4 Vac or greater?	N/A N/A NO: Go to 10.8 YES: Replace LS-671
10.8 Remove VAA from MB Remove CX-13292 from MB Check continuity at CX-13292, Pin K to Pin K	N/A N/A Open?	N/A N/A NO: Go to 10.9 YES: Replace CX-13292
10.9 Check continuity at MB J5, Pin H (RT-A)/Pin P (RT- B) to J3/J4, Pin K	Open?	YES: Replace MB NO: Replace VAA
10.10 Check external devices	CX-13313 or CX-13417 present?	NO: Go to 10.11 YES: Go to 10.3
10.11 Clear alarm at HS	Alarm clears?	YES: Go to 10.12 NO: Go to TS Guide 9
10.12 Check for LS-671 use	LS-671 present?	YES: Go to 10.13 NO: Go to 10.17
10.13 Move HS to LS-671 and clear alarm	Alarm clears?	NO: Go to 10.14 YES: Go to 10.17

3.2. TROUBLESHOOTING GUIDES. Continued

**TS Guide 10. COMSEC ALARM NOT HEARD, OR WILL NOT CLEAR
(EXTERNAL DEVICE) Continued**

STEPS	CHECKS	ACTIONS
10.14 Check installation of CX-13292 and try to clear alarm	CX-13292 improperly installed?	NO: Go to 10.15 YES: Install cable and retry
10.15 Remove VAA and set to LOCAL Move HS to VAA J2/J3 Remove cable from MB J3/J4 Reinstall VAA	N/A N/A N/A Alarm clears?	N/A N/A N/A YES: Go to 10.16 NO: Go to TS Guide 9
10.16 Check continuity at LS-671 J1, Pin A to Pin J	Short?	YES: Replace LS-671 NO: Replace CX-13292
10.17 Connect HS to VAA J2/J3	N/A	Return to Operational Check

TS Guide 11. VARIABLE (COMSEC OR FH DATA) WILL NOT LOAD

STEPS	CHECKS	ACTIONS
11.1 Replace fill cable with known good fill cable Load a variable	N/A Variable loads?	N/A YES: Replaced fill cable is bad NO: Go to 11.2
11.2 Replace fill device battery with known good fill device battery Load a variable	N/A Variable loads?	N/A YES: Replaced battery is bad NO: Go to 11.3
11.3 Replace fill device with known good fill device Load a variable	N/A Variable loads?	N/A YES: Replaced fill device is bad NO: Replace RT

3.2. TROUBLESHOOTING GUIDES. Continued

TS Guide 12. FAILED FORWARD AND REVERSE POWER CHECK

STEPS	CHECKS	ACTIONS
12.1 Remove veh ant cable from ant base Connect dummy load to vehicle antenna cable Set test set MODE to FWD PWR Press PTT and PTest	N/A N/A N/A FWD PWR more than 2 W?	N/A N/A N/A YES: Go to 12.2 NO: Replace RT
12.2 Set test set MODE to RVS PWR Press PTT and PTest	N/A RVS PWR less than 0.3 W?	N/A YES: Go to 12.3 NO: Replace veh ant cable
12.3 Remove ant cable from dummy load Connect ant cable to vehicle antenna base	N/A Is antenna system clean?	N/A NO: Go to 12.4 YES: Go to 12.5
12.4 Clean ant elm contacts Clean ant GND straps Clean rust from ant mounting hardware Re-measure FWD/RVS PWR	N/A N/A N/A RVS PWR high? *	N/A N/A N/A YES: Go to 12.5 NO: UUT is now Operational
12.5 Replace ant elements Re-measure FWD/RVS PWR	N/A RVS PWR high? *	N/A YES: Replace ant base NO: Replaced ant elements are bad

- * Reverse Power Check: 1. Measure Forward Power and Reverse Power
 2. Divide Forward Power by Reverse Power
 3. If result is 3.0 or MORE, RVS PWR is normal for voice
 4. If result is 4.0 or MORE, RVS PWR is normal for data

TS Guide 13. NO SIDETONE WITH FORWARD/REVERSE POWER CORRECT

STEPS	CHECKS	ACTIONS
13.1 Remove W4 from RT AUD/DATA Move HS to RT AUD/FILL Press PTT; count into HS	N/A N/A Sidetone heard?	N/A N/A YES: Go to 13.2 NO: Replace RT
13.2 Move HS to RT AUD/DATA Press PTT; count into HS	N/A Sidetone heard?	N/A YES: Go to 13.3 NO: Replace RT
13.3 Check continuity of W4, Pin D to Pin D	Open?	YES: Replace W4 cable NO: Replace VAA

3.2. TROUBLESHOOTING GUIDES. Continued

TS Guide 14. FORWARD POWER INCORRECT THRU PA IN RF PWR HI

STEPS	CHECKS	ACTIONS
14.1 Define problem	FWD PWR greater than 6 W?	NO: Go to 14.2 YES: Go to 14.5
14.2 Remove test set cable from RADIO Remove RF cable from PA J2 Connect W2 to test set RADIO Press PTT and PTTTest	N/A N/A N/A FWD PWR 2-6 W?	N/A N/A N/A YES: Go to 14.3 NO: Replace W2*
14.3 Remove PA Measure voltages at VAA J1 (RT-A) or PA Mount J4 (RT- B): Pin B 6.55-6.95 Vdc Pin C 12.5- 13.5 Vdc ** Pin D 22.0-32.0 Vdc Pin F 180-220 Vdc	N/A All voltages correct?	N/A No: Go to 14.4 YES: Replace RT
14.4 Define problem	Is RT - A UUT?	YES: Replace VAA NO: Replace PA Mount
14.5 Remove PA Press PTT Measure voltage at VAJ1 J1 or PA Mount J4, Pin N to Pin A (GND)	N/A N/A (-)0.5-0.5 Vdc?	N/A N/A YES: Replace PA NO: Replace RT

* Or CG-3856

WARNING: VAA J1 and PA MOUNT J4 have 200 VDC on Pin F. Use extreme caution in measuring voltage.

3.2. TROUBLESHOOTING GUIDES. Continued

TS Guide 15. RT-A: LESS THAN 30W FWD PWR OUT OF PA FROM 30-40 MHZ

STEPS	CHECKS	ACTIONS
15.1 Start veh engine Re-measure FWD PWR	N/A FWD PWR greater than 30 w?	N/A NO: GO to 15.2 YES: Problem is with vehicle power
15.2 Remove W2 from RT-A Remove PA Connect test set cable from RT ANT to test set RADIO Press PTT Measure voltage at VAA J1, Pin N to Pin A (GND)	N/A N/A N/A N/A 6-7 Vdc?	N/A N/A N/A N/A NO: Go to 15.3 YES: Go to 15.4
15.3 Remove RT Check continuity at VAA J1, Pin N to J8, Pin H	N/A Open?	N/A NO: Replace RT YES: Replace VAA
15.4 Press PTT Measure voltage at VAA J1, Pin P to Pin A (GND)	N/A 6-7 Vdc?	N/A NO: Go to 15.5 YES: Go to 15.6
15.5 Remove RT Check continuity at VAA J1, Pin P to J8, Pin M	N/A Open?	N/A NO: Replace RT YES: Replace VAA
15.6 Measure voltages at VAA J1: Pin B 6.55-6.95 Vdc Pin C 12.5 -13.5 Vdc Pin D 22.0-32.0 Vdc * Pin F 180-220 Vdc	All voltages correct?	YES: Replace PA NO: Replace VAA

WARNING: VAA J1 and PA MOUNT J4 have 200 VDC on Pin F.
Use extreme caution in measuring voltage.

3.2. TROUBLESHOOTING GUIDES. Continued

TS Guide 16. RT-B: LESS THAN 30W FWD PWR OUT OF PA FROM 30-40 MHZ

STEPS	CHECKS	ACTIONS
16.1 Start veh engine Measure FWD PWR	N/A FWD PWR greater than 30 W?	N/A NO: Go to 16.2 YES: Problem is with vehicle power
16.2 Remove CG-3856 from RT Remove PA Connect test set cable from RT ANT to test set RADIO Press PTT Measure voltage at PA Mount J4, Pin N to Pin A (GND)	N/A N/A N/A N/A 6-7 Vdc?	N/A N/A N/A N/A NO: Go to 16.3 YES: Go to 16.6
6.3 Remove CX-13291 from PA Mount J3 Press PTT Measure voltage at CX-13291 P1, Pin N to Pin A (GND)	N/A N/A 6-7 Vdc?	N/A N/A NO: Go to 16.4 YES: Replace PA Mount
16.4 Remove VAA from MB Check continuity at VAA J11, Pin N to J7, Pin H	N/A Open?	N/A NO: Go to 16.5 YES: Replace VAA
16.5 Remove CX-13291 from VAA J11 Check continuity at CX-13291 P1, Pin N to P2, Pin N	N/A Open?	N/A YES: Replace CX-13291 NO: Replace RT
16.6 Press PTT Measure voltage at PA Mount J4, Pin P to Pin A (GND)	N/A 6-7 Vdc?	N/A NO: Go to 16.7 YES: Go to 16.10
6.7 Remove CX-13291 from PA Mount J3 Press PTT Measure voltage at cable, Pin P to Pin A (GND)	N/A N/A 6-7 Vdc?	N/A N/A NO: Go to 16.8 YES: Replace PA Mount
16.8 Remove VAA from MB Check continuity at VAA J11, Pin P to J7, Pin M	N/A Open?	N/A NO: Go to 16.9 YES: Replace VAA
16.9 Remove CX-13291 from VAA J11 Check continuity at CX-13291 P1, Pin P to P2, Pin P	N/A Open?	N/A YES: Replace CX-13291 NO: Replace RT
16.10 Measure voltages at PA Mount J4: Pin B 6.55-6.95 Vdc Pin C 12.5- 13.5 Vdc * Pin D 22.0-32.0 Vdc Pin F 180-220 Vdc	All voltages correct?	YES: Replace PA NO: Replace PA Mount

**WARNING: VAA J1 and PA MOUNT J4 have 200 VDC on Pin F.
Use extreme caution in measuring voltage.**

3.2. TROUBLESHOOTING GUIDES. Continued

**TS Guide 17. RT-A: LESS THAN 30W FWD PWR OUT OF PA
FROM EITHER 43-61.4 MHZ OR 61.4-88 MHZ**

STEPS	CHECKS	ACTIONS
17.1 Remove PA Connect test set cable from RT ANT to test set RADIO Press PTT Measure voltage at VAA J1: * 54000 (CHAN 2) Pin R to Pin A (GND) 75000 (CHAN 3) Pin M to Pin A (GND)	N/A N/A N/A 6-7 Vdc?	N/A N/A N/A YES: Go to 17.2 NO: Replace PA
17.2 Remove RT from VAA Check continuity at VAA 54000 (CHAN 2) J8, Pin R to J1, Pin L 75000 (CHAN 3) J8, Pin M to J1, Pin V	N/A Open?	N/A NO: Replace RT YES: Replace VAA

**TS Guide 18. RT-B: LESS THAN 30W FWD PWR OUT OF PA
FROM EITHER 43-61.4 MHZ OR 61.4-88 MHZ**

STEPS	CHECKS	ACTIONS
18.1 Remove PA Connect test set cable from RT ANT to test set RADIO Press PTT Measure voltage at PA Mount J4: * 54000 (CHAN 2) Pin R to Pin A (GND) 75000 (CHAN 3) Pin M to Pin A (GND)	N/A N/A N/A 6-7 Vdc?	N/A N/A N/A NO: Go to 18.2 YES: Replace PA
18.2 Remove CX-13291 from PA Mount J3 Press PTT Measure voltage at CX-13291: * 54000 (CHAN 2) Pin R to Pin A (GND) 75000 (CHAN 3) Pin M to Pin A (GND)	N/A N/A 6-7 Vdc?	N/A N/A NO: Go to 18.3 YES: Replace PA Mount
18.3 Remove RT-B Remove VAA from MB Check continuity at VAA 54000 (CHAN 2) J11, Pin R to J7, Pin L 75000 (CHAN 3) J11, Pin M to J7, Pin V	N/A N/A Open?	N/A N/A NO: Go to 18.4 YES: Replace VAA
18.4 Check continuity at CX-13291: 54000 (CHAN 2) P1, Pin R to P2, Pin R 75000 (CHAN 3) P1, Pin M to P2, Pin M	Open?	YES: Replace CX-13291 NO: Replace RT

WARNING: VAA J1 and PA MOUNT J4 have 200 VDC on Pin F. Use extreme caution in measuring voltage.
--

3.2. TROUBLESHOOTING GUIDES. Continued

TS Guide 19. RT SIG DISPLAY INCORRECT WITH RF PWR SET TO PA

STEPS	CHECKS	ACTIONS
19.1 Replace PA Press PTT	N/A RT SIG display reads 6?	N/A NO: Go to 19.2 YES: Replaced PA is bad
19.2 Replace RT Press PTT	N/A RT SIG display reads 6?	N/A NO: Go to 19.3 YES: Replaced RT is bad
19.3 Define problem	RT-A is UUT?	NO: Go to 19.4 YES: Replace VAA
19.4 Remove PA from PA Mount Remove CX-13291 from PA Mount J3 Check continuity at PA Mount J3, Pin k to J4, Pin K	N/A N/A Open?	N/A N/A NO: Go to 19.5 YES: Replace PA Mount
19.5 Remove RT-B Remove CX-13291 from VAA J11 Check continuity at VAA J11, Pin K to J7, Pin J	N/A N/A Open?	N/A N/A YES: Replace VAA NO: Replace CX-13291

3.2. TROUBLESHOOTING GUIDES. Continued

**TS Guide 20. RT SIG DISPLAY DOES NOT LIGHT
WHEN LS-671 PTT IS PRESSED**

STEPS	CHECKS	ACTIONS
20.1 Remove W4 from VAA J5 (RT-A)/J4 (RT-B) Measure voltage at VAA J4/J5, Pin C to outside of connector	N/A 1-2.5 Vdc?	N/A YES: Go to 20.2 NO: Replace VAA
20.2 Define problem	CX-13417 present at MB?	YES: Go to 20.3 NO: Go to 20.6
20.3 LS-671 to OFF Remove VAA fro MB Remove CX-13417 from MB J3 (RT-A)/J4 (RT-B) Check continuity at MB J5, Pin K (RT-A)/Pin S (RT-B) to J3/J4 Pin S	N/A N/A N/A Open?	N/A N/A N/A NO: Go to 20.4 YES: Replace MB
20.4 Remove CX-13292 from CX-13417 Remove CX-1 3417 from MB J3/J4 Connect CX-1 3292 to MB J3/J4 Press LS-671 HS PTT	N/A N/A N/A RT SIG display lights?	N/A N/A N/A NO: Go to 20.5 YES: Replace CX-13417
20.5 Remove CX-13292 from LS-671 J1 and MB J3/J4 Check continuity at CX-13292 P1, Pin J to P2, Pin S*	N/A Open?	N/A YES: Replace CX-13292 NO: Replace LS-671
20.6 Set LS-671 CB1 to OFF Remove VAA from MB Remove CX-13292 from MB J3/J4 Check continuity at MB J5, Pin K (RT-A) /Pin S (RT-B) to J3/J4 Pin S	N/A N/A N/A Open?	N/A N/A N/A NO: Go to 20.7 YES: Replace MB
20.7 Remove CX-13292 from LS-671 J1 Check continuity at CX-1 3292 P1, Pin J to P2, Pin S	N/A Open?	N/A YES: Replace CX-13292 NO: Replace LS-671

* P1 is speaker end; P2 is radio end.

3.2. TROUBLESHOOTING GUIDES. Continued

TS Guide 21. NO SIDETONE HEARD AT LS-671

STEPS	CHECKS	ACTIONS
21.1 Define problem	CX-13417 present at MB?	NO: Go to 21.2 YES: Go to 21,6
21.2 Set LS-671 CB1 to OFF Remove VAA from MB Measure resistance at VAA: (RT-A) J3 Pin D to P1 Pin M (RT-B) J4 Pin D to P1 Pin U	N/A N/A Resistance more than 20K or less than 28K Ohms?	N/A N/A YES: Go to 21.3 NO: Replace VAA
21.3 Remove CX-13292 from MB J3/J4 Check continuity at MB J5, Pin U to J3/J4, Pin U	N/A Open?	N/A NO: Go to 21.4 YES: Replace MB
21.4 Remove CX-13292 from LS-671 J1 Check continuity at MB: (RT-A) J3 Pin D to P1 Pin M (RT-B) J4 Pin D to P1 Pin U	N/A Open?	N/A NO: Go to 21.5 YES: Replace CX-13292
21.5 Check continuity at CX-13292 P1, Pin S to P2, Pin A*	Open?	YES: Replace CX-13292 NO: Replace LS-671
21.6 Set LS-671 CB1 to OFF Remove CX-13417 from MB J3/J4 Remove CX-13292 from CX-13417 Connect CX-13292 to MB J3/J4 Set LS-671 CB1 to ON Press PTT; count into HS	N/A N/A N/A N/A N/A Sidetone heard?	N/A N/A N/A N/A N/A YES: Replace CX-13417 NO: Go to 21.2

* P1 is speaker end; P2 is radio end.

TS Guide 22. RADIO WILL NOT OPERATE WITH DATA DEVICES

STEPS	CHECKS	ACTIONS
22.1 Run self-test on RT	Self-test failed?	NO: Go to 22.2 YES: Replace RT
22.2 Run self-test on data device	Self-test failed?	NO: Go to 22.3 YES: Replace data device
22.3 Test interface cable	Open or shorted?	NO: Go to 22.4 YES: Replace cable
22.4 Replace data device with known good data device* Operate system	N/A System operates?	N/A NO: Replace RT YES: Replaced data device is bad

* If data device is not available, replace RT. If system then operates, RT was bad.

SECTION IV

CABLE SCHEMATICS

COMMON NAME	NOMENCLATURE	PAGE
4.1 RF Cable	CG-3855	4-2
4.2 RF Cable and W2	CG-3856	4-2
4.3 PA Control Cable	CX-13291	4-3
4.4 LS-671 Cable	CX-13292	4-3
4.5 RXMT Cable	CX-13298	4-4
4.6 Intercom Cable	CX-13300	4-4
4.7 M551 Power Cable	CX-13301	4-5
4.8 Power Cable	CX-13302	4-5
4.9 Power Cable	CX-13303	4-6
4.10 Power Cable	CX-13304	4-6
4.11 Power Cable	CX-13305	4-7
4.12 Power Cable	CX-13306	4-7
4.13 DMD (Data) Cable	CX-13308	4-8
4.14 HYX-57 Cable	CX-13310	4-8
4.15 MST-20 Adapter Cable	CX-13311	4-9
4.16 PSC-3 Adapter Cable	CX-13312	4-9
4.17 VIC Interface Cable	CX-13313	4-10
4.18 TACFIRE Magic Cable	CX-13402	4-10
4.19 Splitter Cable	CX-13417	4-11
4.20 Power Cable	CX-13450	4-11
4.21 Digital Adapter Cable	CX-13465	4-12
4.22 Audio/Data Cable	W4	4-12

4.1. CG-3855 (RF Cable)

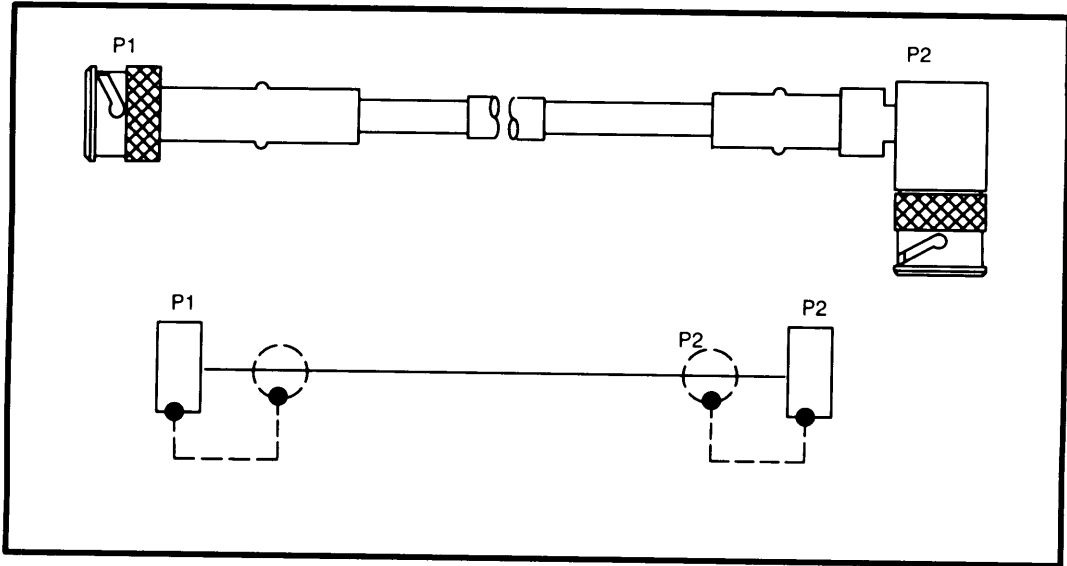

CG-3855 (RF Cable)

4.2. CG-3856 (RF Cable)*

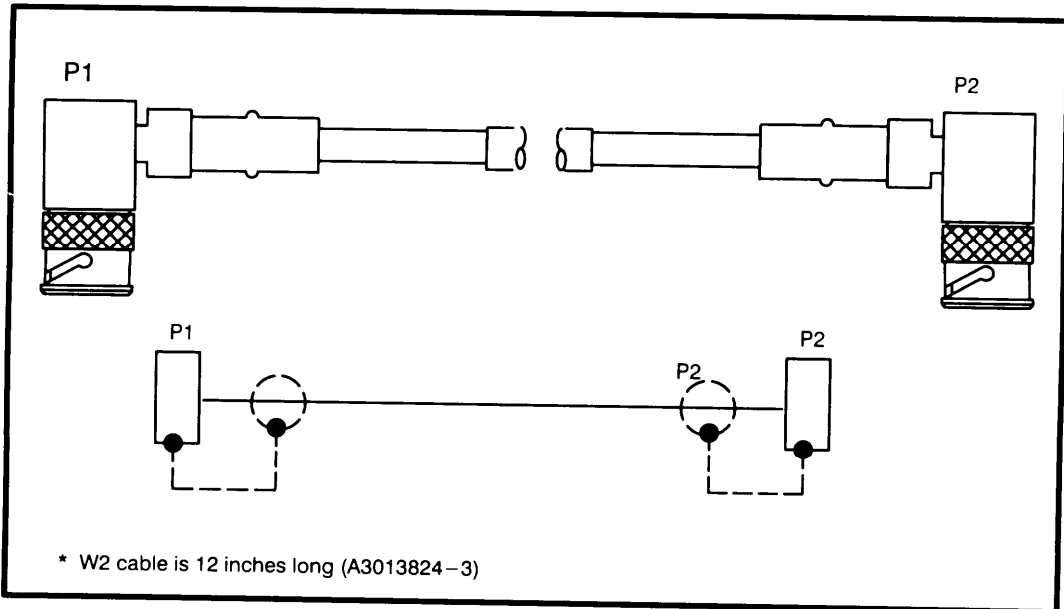

CG-3856 (RF Cable & W2)

4.3. CX-13291 (PA Control Cable)

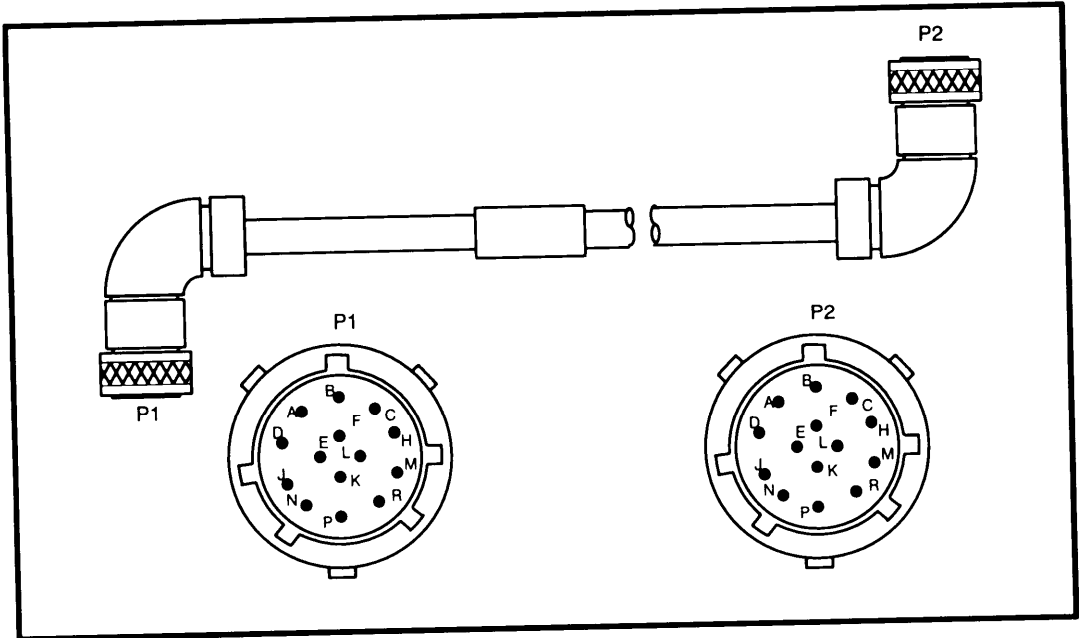

CX-13291 (PA Control Cable)

4.4. CX-13292 (LS-671 Cable)

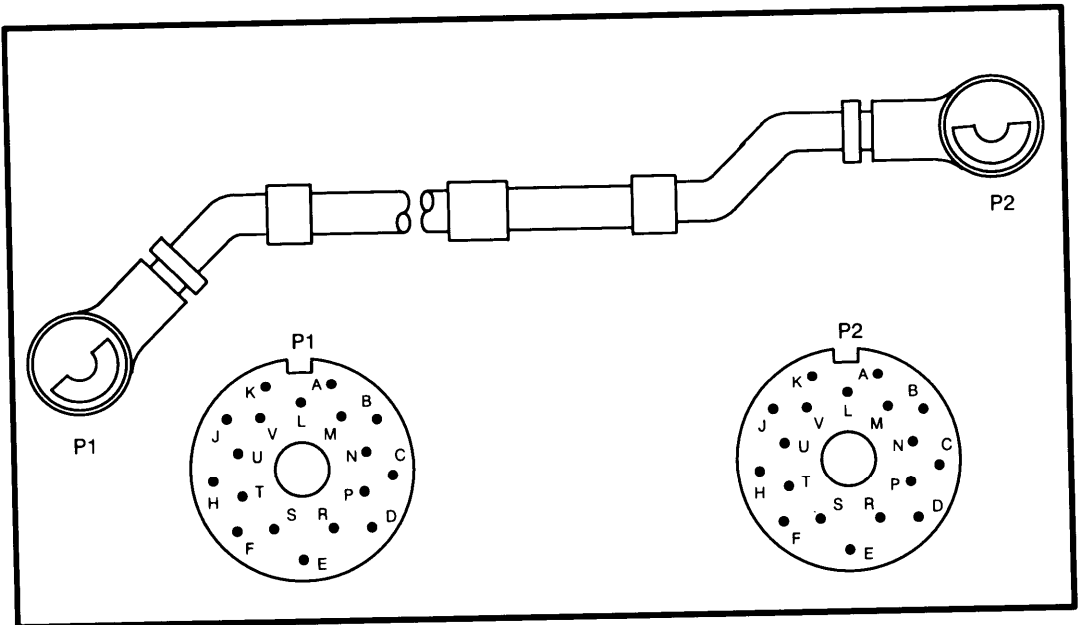

CX-13292 (LS-671 Cable)

NOTE: \bullet filled-in indicates male connector
 \circ not filled-in indicates female connector

4.5. CX-13298 (RXMT Cable)

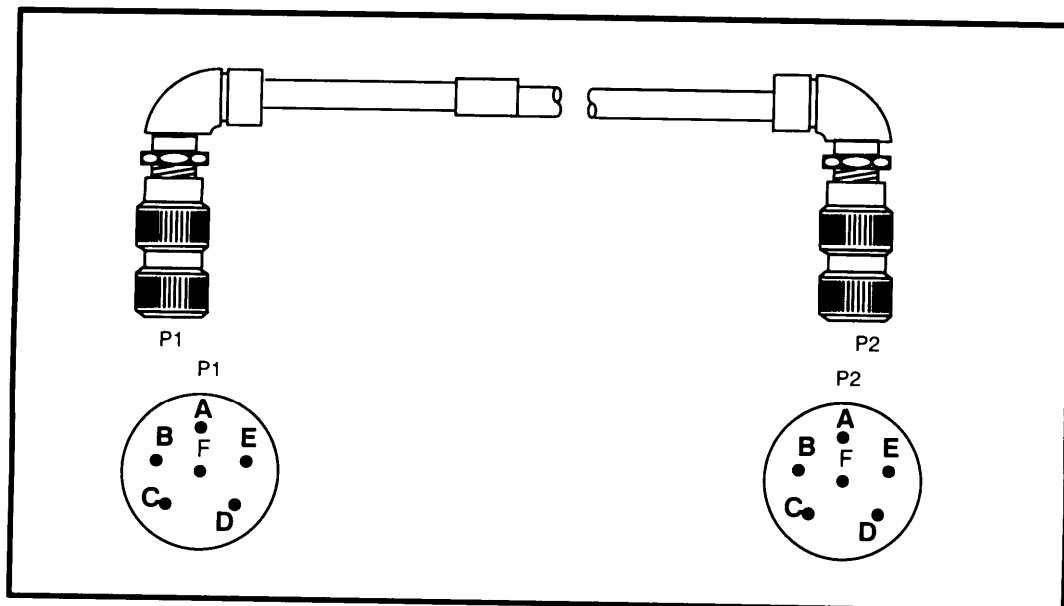

CX-13298 (RXMT Cable)

4.6. CX-13300 (Intercom Cable)

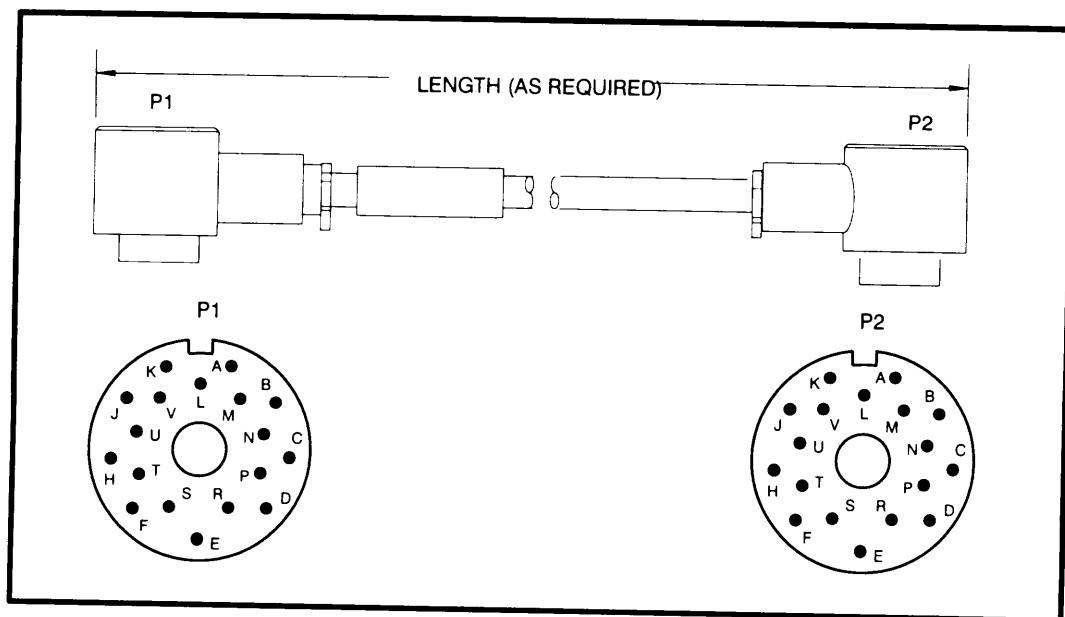

CX-13300 (Intercom Cable)

4.7. CX-13301 (M551 Power Cable)

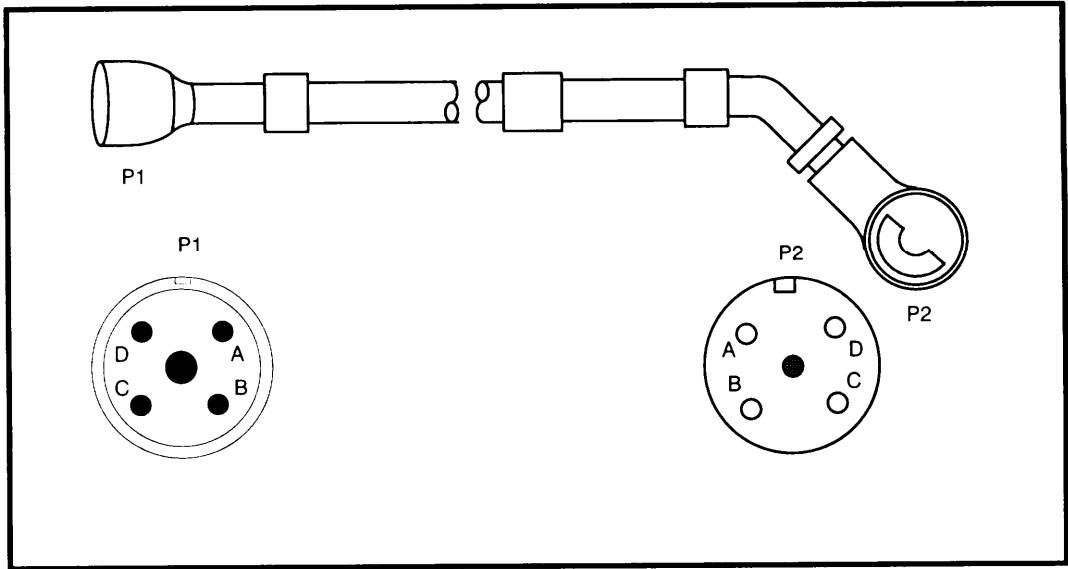

CX-13301 (M551 Power Cable)

4.8. CX-13302 (Power Cable)

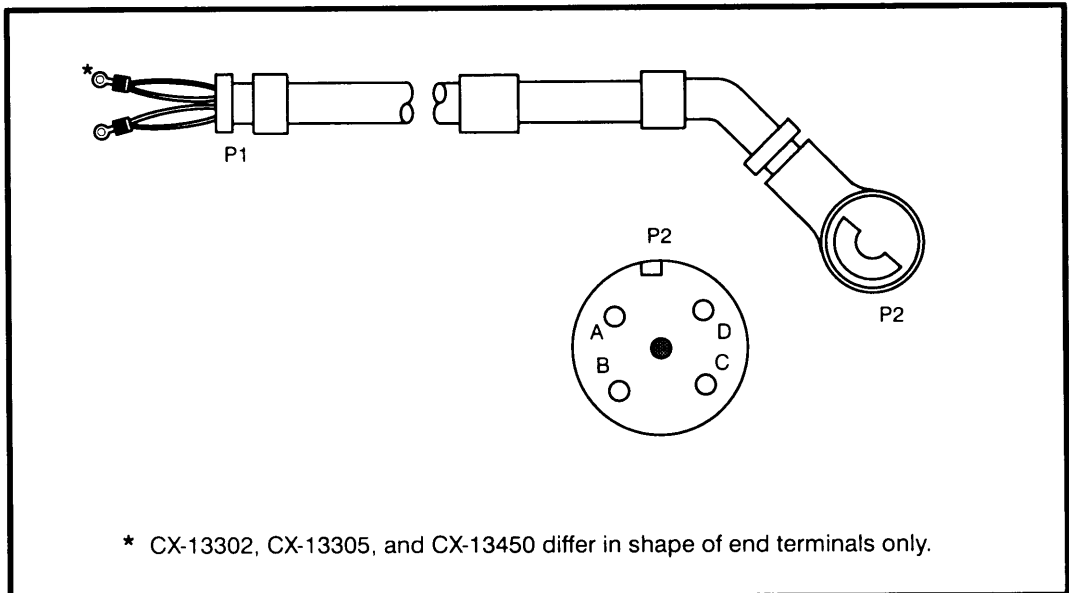

4.9. CX-13303 (Power Cable)

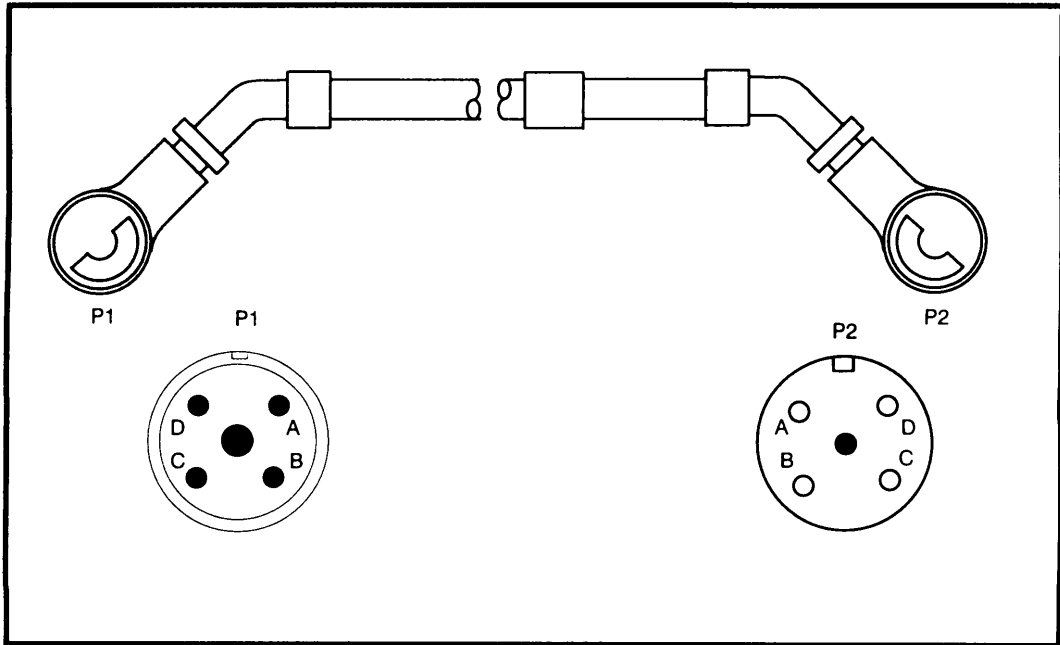

CX-13303 (Power Cable)

4.10. CX-13304 (Power Cable)

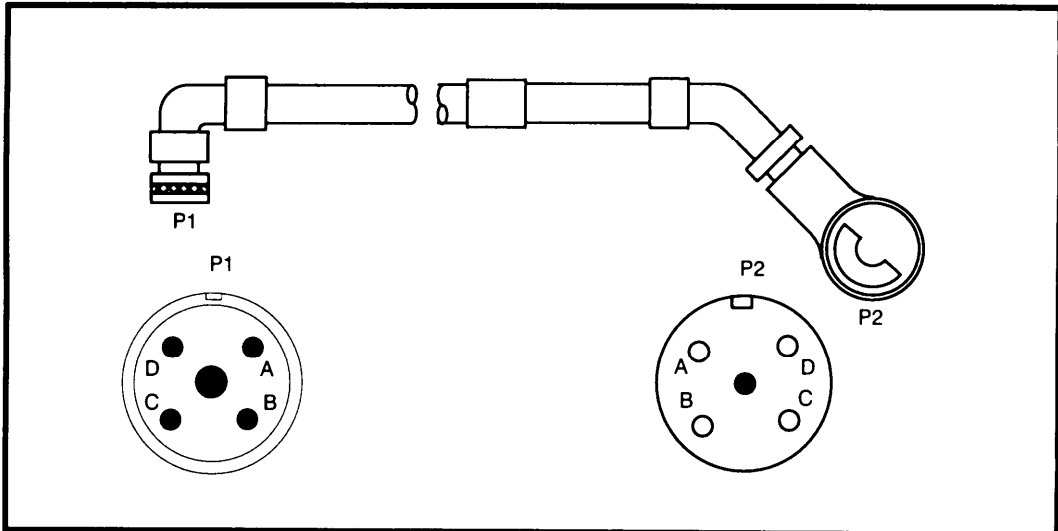

CX-13304 (Power Cable)

4.11. CX-13305 (Power Cable)

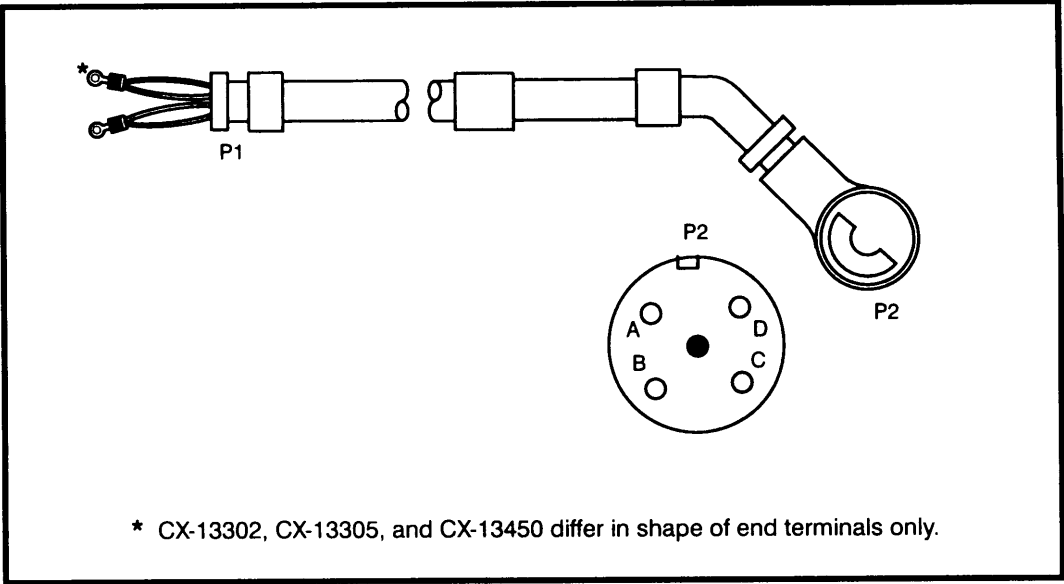

CX-13305 (Power Cable)

4.12. CX-13306 (Power Cable)

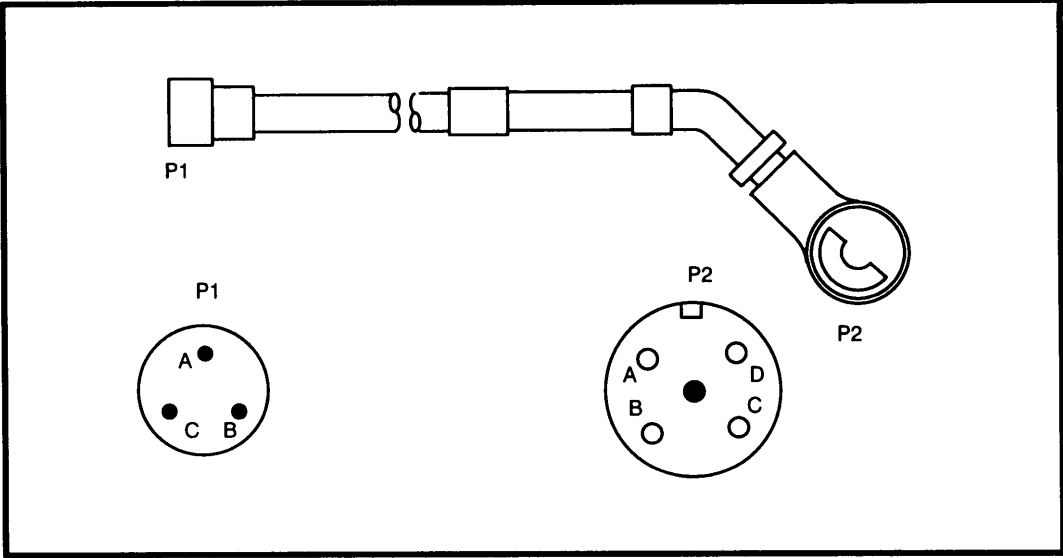

CX-13306 (Power Cable)

4.13. CX-13308 (DMD Data Cable)

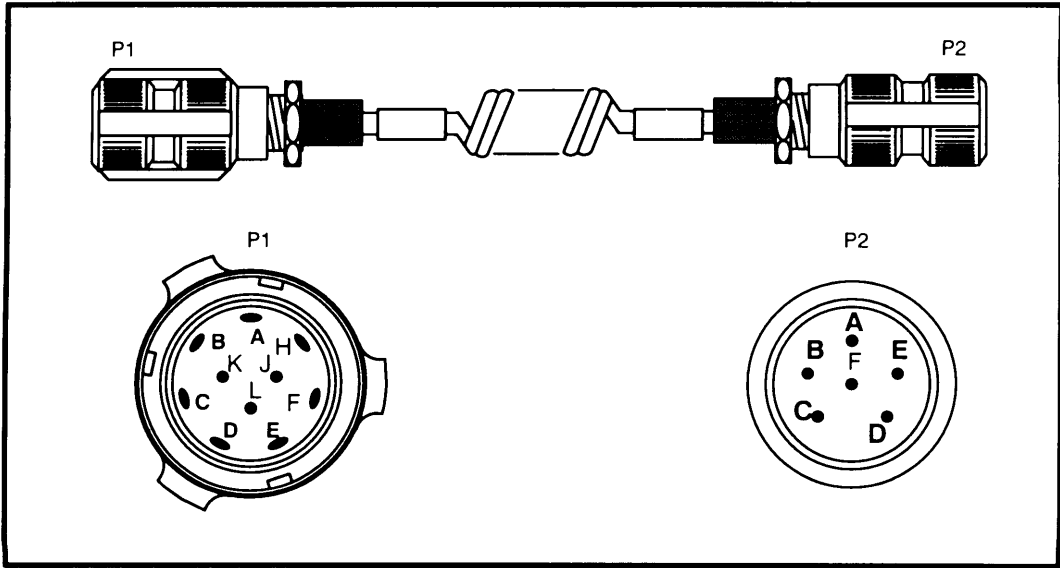

CX-13308 (DMD Data Cable)

4.14. CX-13310 (HYX-57 Cable)

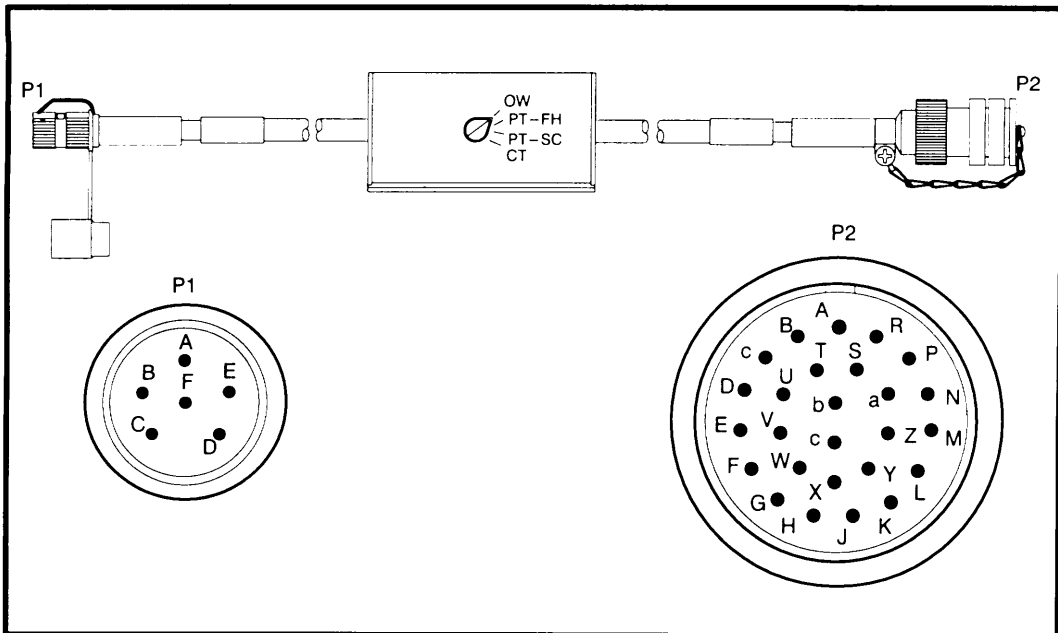

CX-13310 (HYX-57 Cable)

4.15. CX-13311 (MST-20 Adapter Cable)

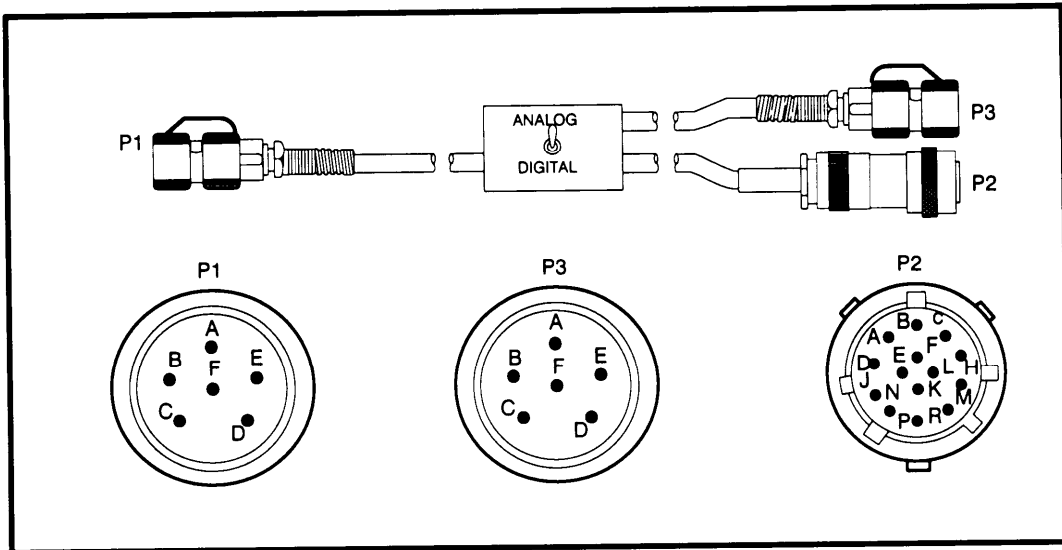

CX-13311 (MST-20 Adapter Cable)

4.16. CX-13312 (PSC-3 Adapter Cable)

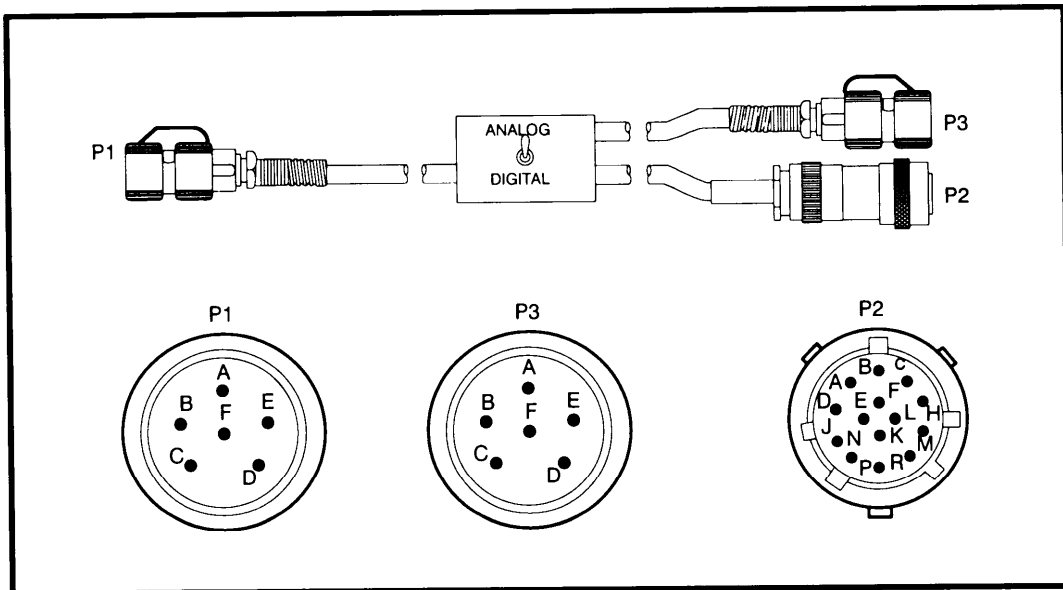

CX-I 3312 (PSC-3 Adapter Cable)

4.17. CX-13313 (WC Interface Cable)

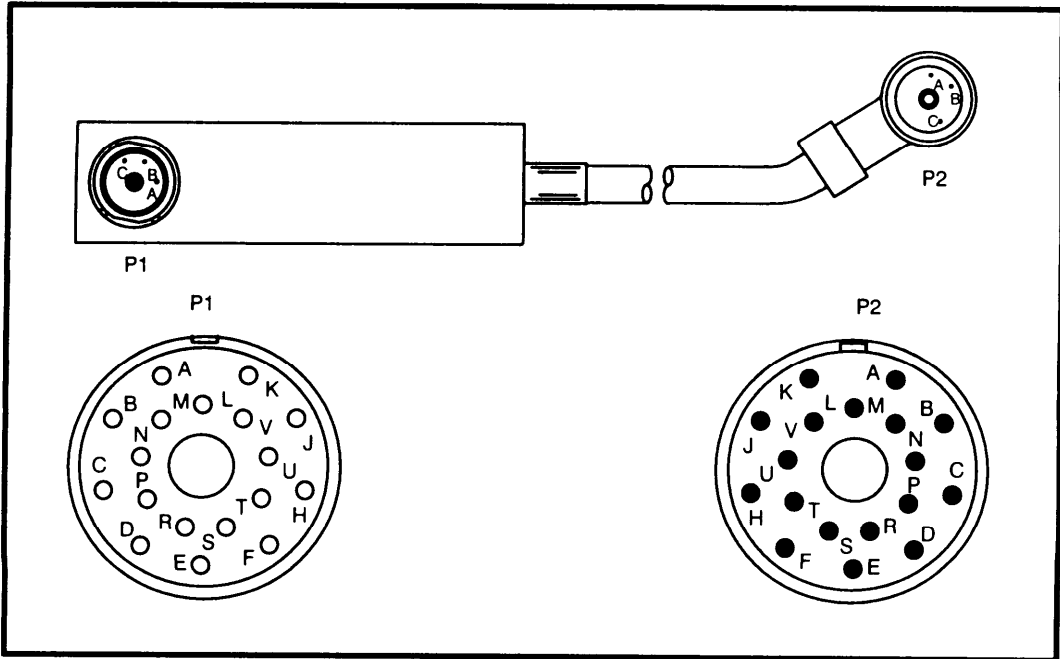

CX-13313 (WC Interface Cable)

4.18. CX-13402 (TACFIRE "Magic" Cable)

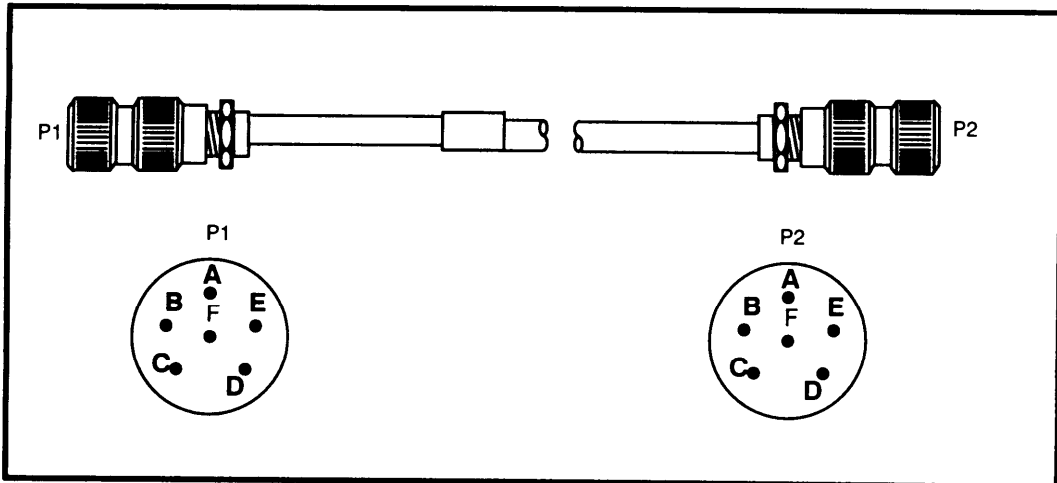

CX-13402 (TACFIRE "Magic" Cable)

4.19. CX-13417 (Splitter Cable)

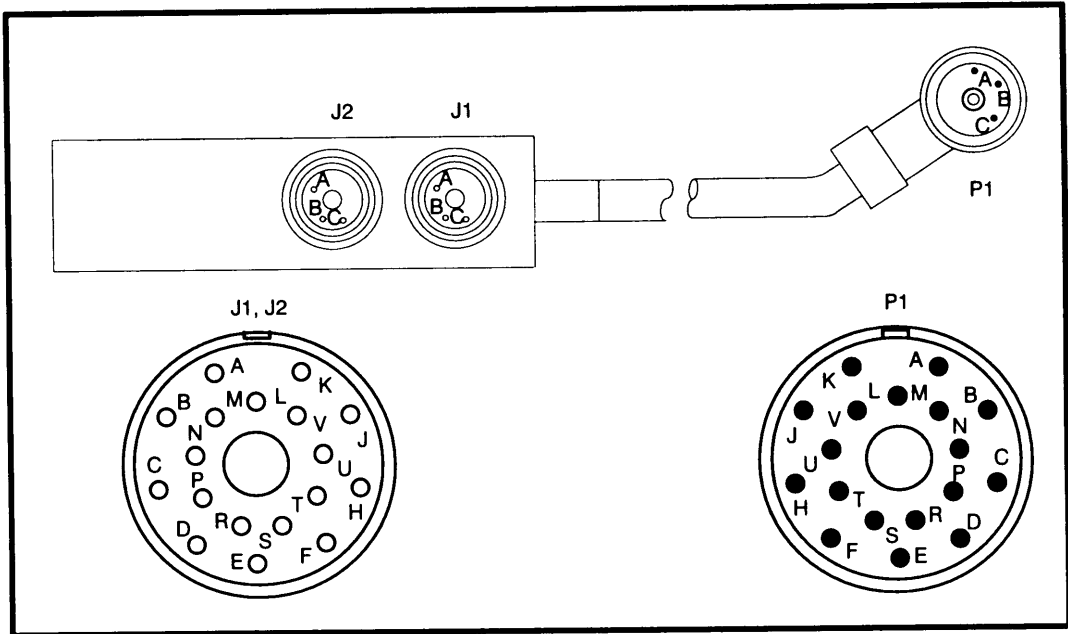

CX-13417 (Splitter Cable)

4.20. CX-13450 (Power Cable)

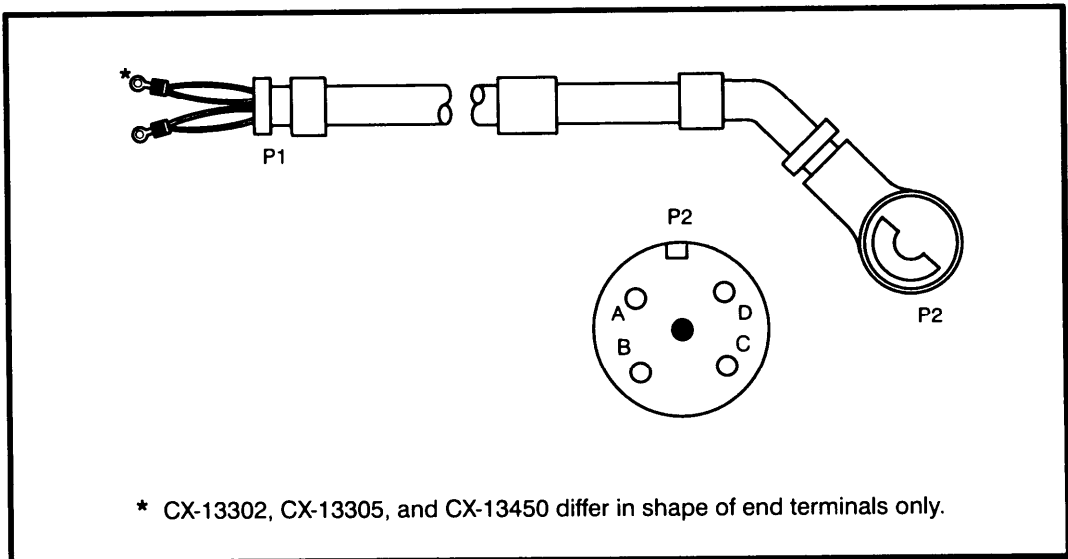

CX-13450 (Power Cable)

4.21. CX-13465 (Digital Adapter Cable)

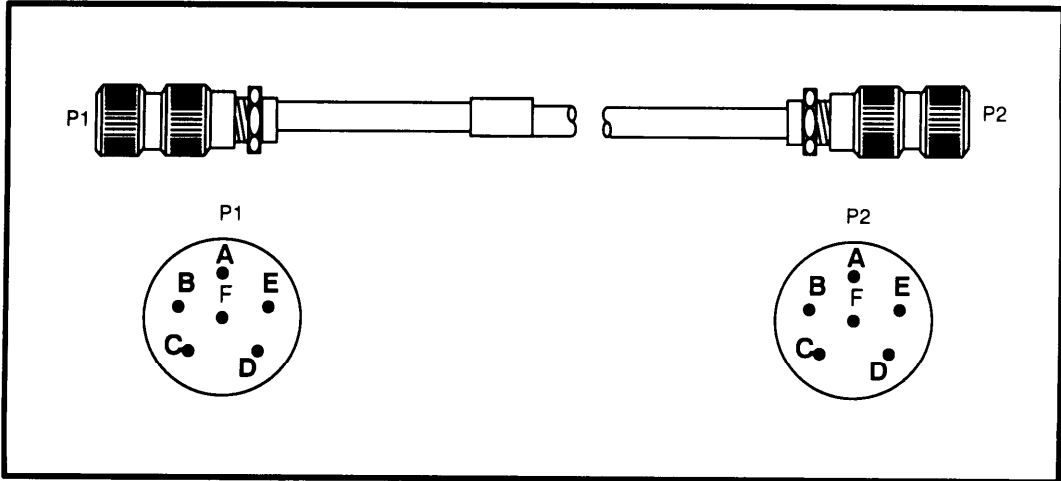

CX-13465 (Digital Adapter Cable)

4.22. W4 (Audio/Data Fill Cable)

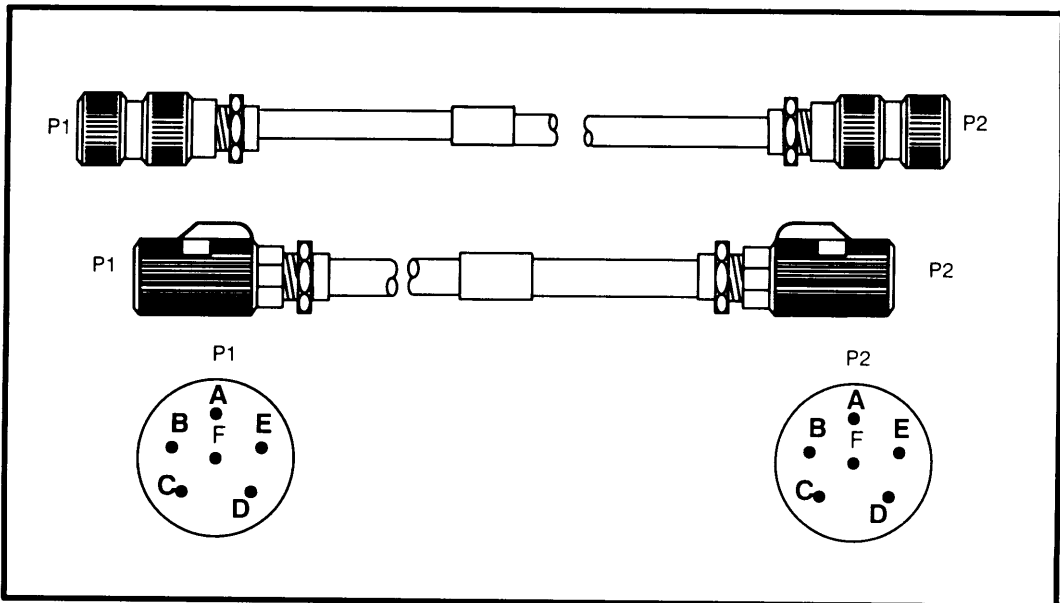

W4 (Audio/Data Fill Cable)

SECTION V**SELECTED GRAPHICS**

ITEM	PAGE
5.1 Mounting Base (MB) (MT-6352 Series)	5-2
5.2 Vehicular Amplifier Adapter (VAA) (AM-7239 Series)	5-2
5.3 RF Power Amplifier (PA) (AM-7238 Series)	5-3
5.4 Receiver-Transmitter (RT) (RT-1523 Series)	5-3
5.5 Remote Control Unit (RCU) (C-11561)	5-4
5.6 Control-Monitor (CM) (C-11291)	5-4
5.7 Loudspeaker (LS) (LS-671)	5-5
5.8 Handset (HS) (H-250)	5-5
5.9 Short Range Radio/RT-A	5-6
5.10 Short Range Radio/RT-B	5-7
5.11 Long Range Radio/RT-A	5-8
5.12 Long Range Radio/RT-B	5-9

5.1.

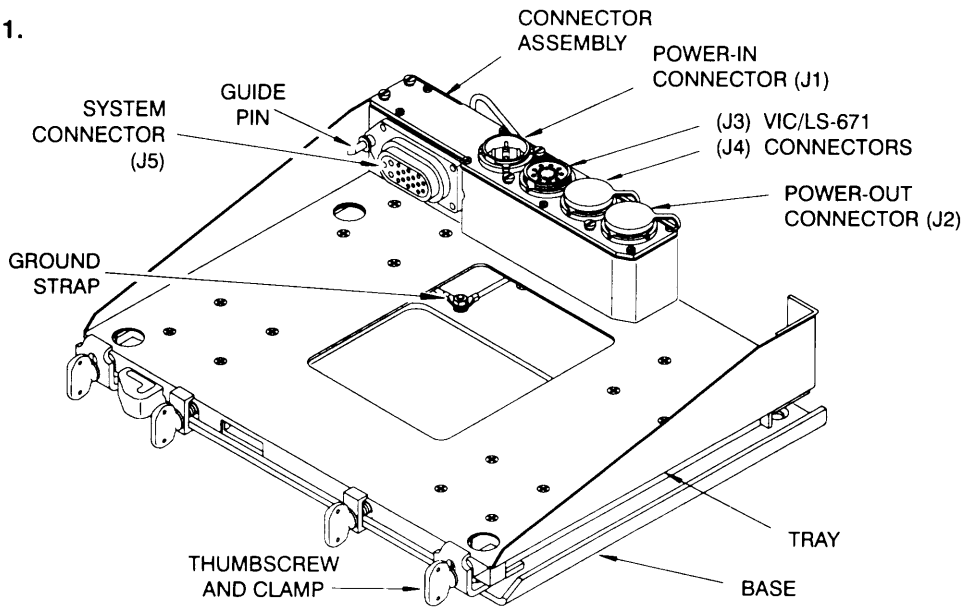

MOUNTING BASE (MB) (MT-6352 Series)

5.2.

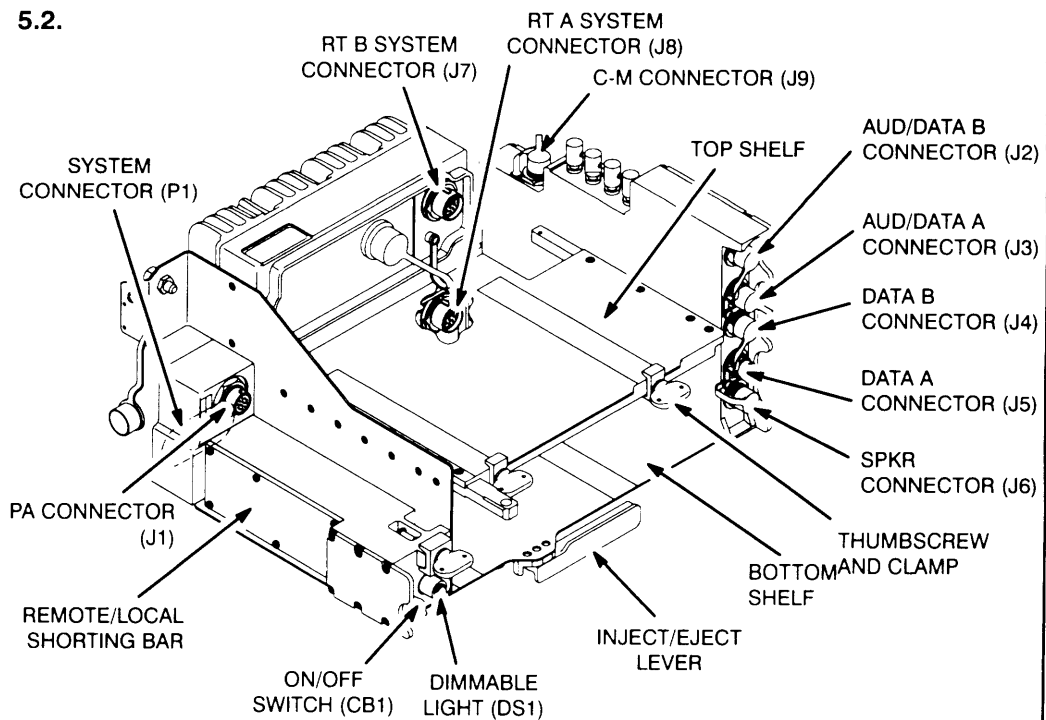

VEHICULAR AMPLIFIER ADAPTER (VAA) (AM-7239 Series)

5.3.

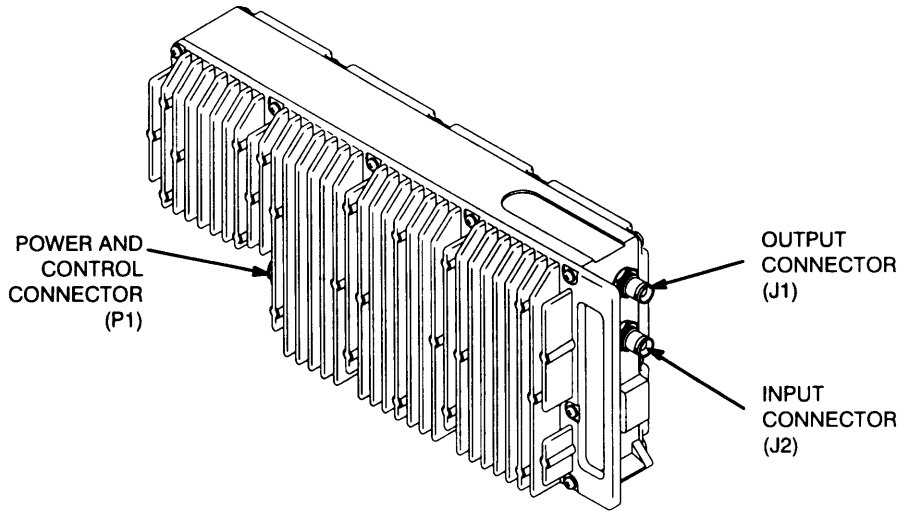

RF POWER AMPLIFIER (PA) (AM-7238 Series)

5.4.

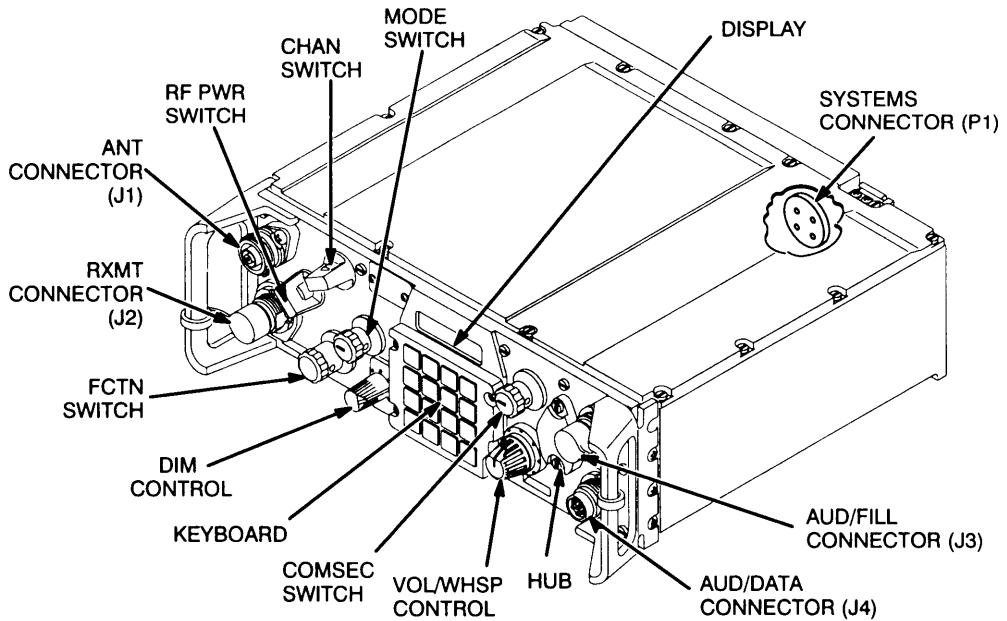

RECEIVER-TRANSMITTER (RT) (RT-1523 Series)

5.5.

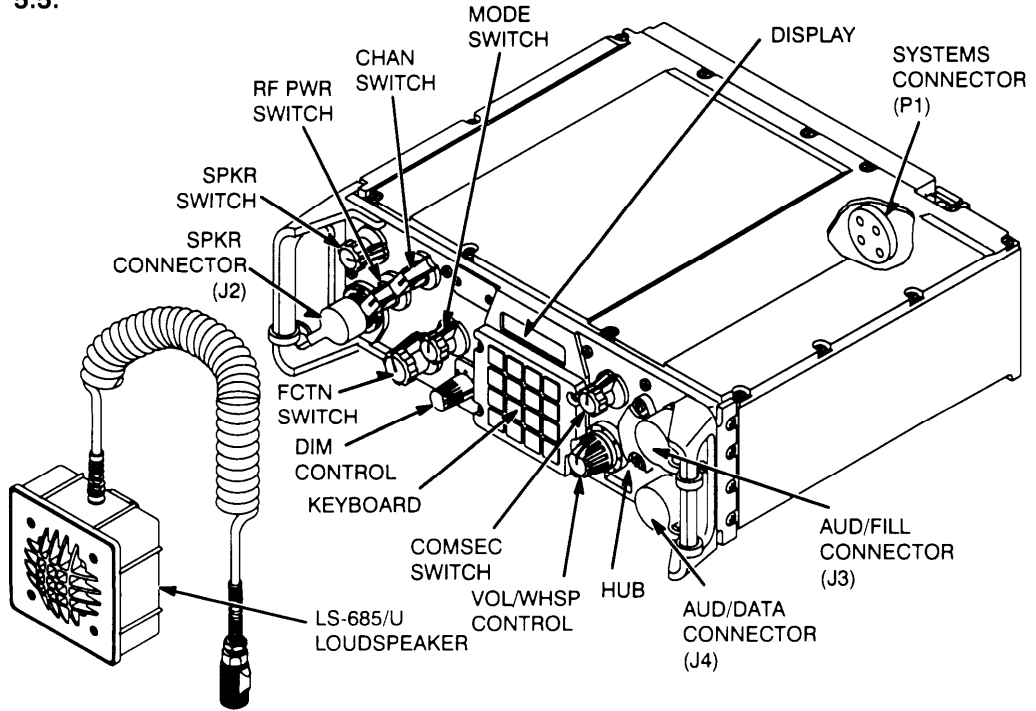

REMOTE CONTROL UNIT (RCU) (C-11561)

5.6.

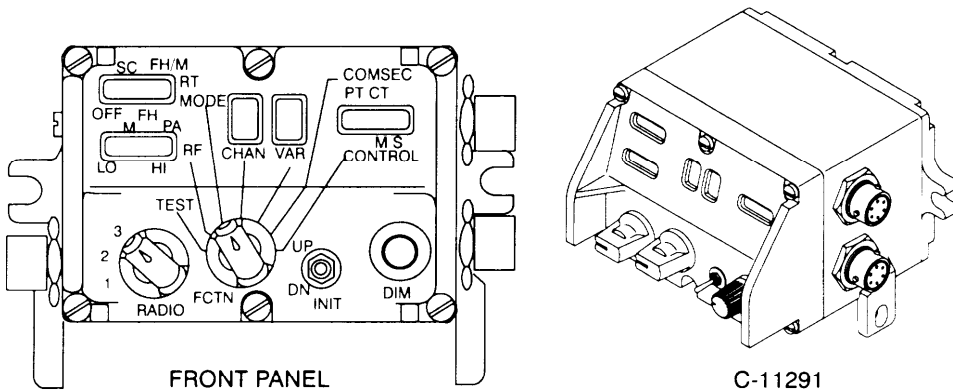

CONTROL-MONITOR (CM) (C-11291 Series)

5.7.

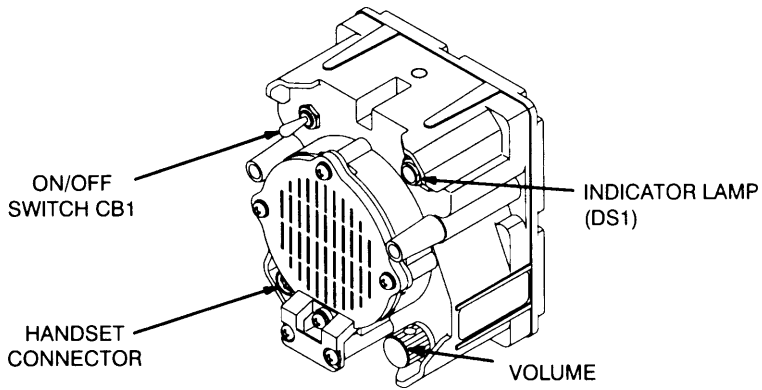

LOUDSPEAKER (LS) (LS-671)

5.8.

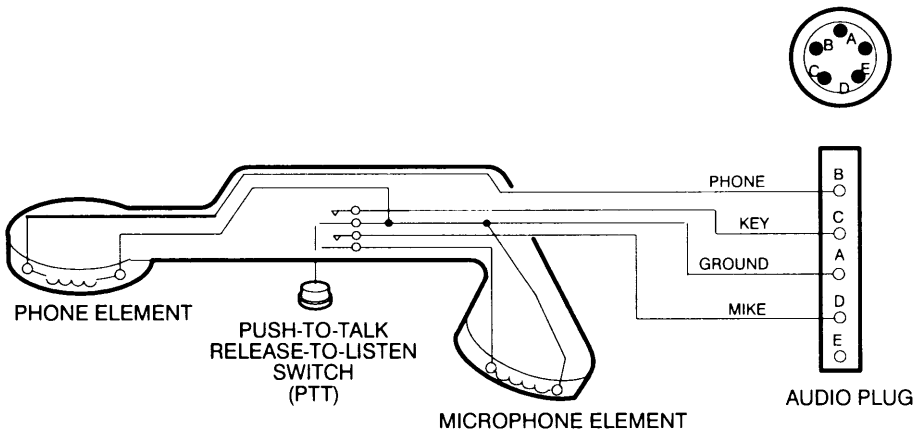

HANDSET (HS) (H-250)

5.9. SHORT RANGE RADIO/RT (A)

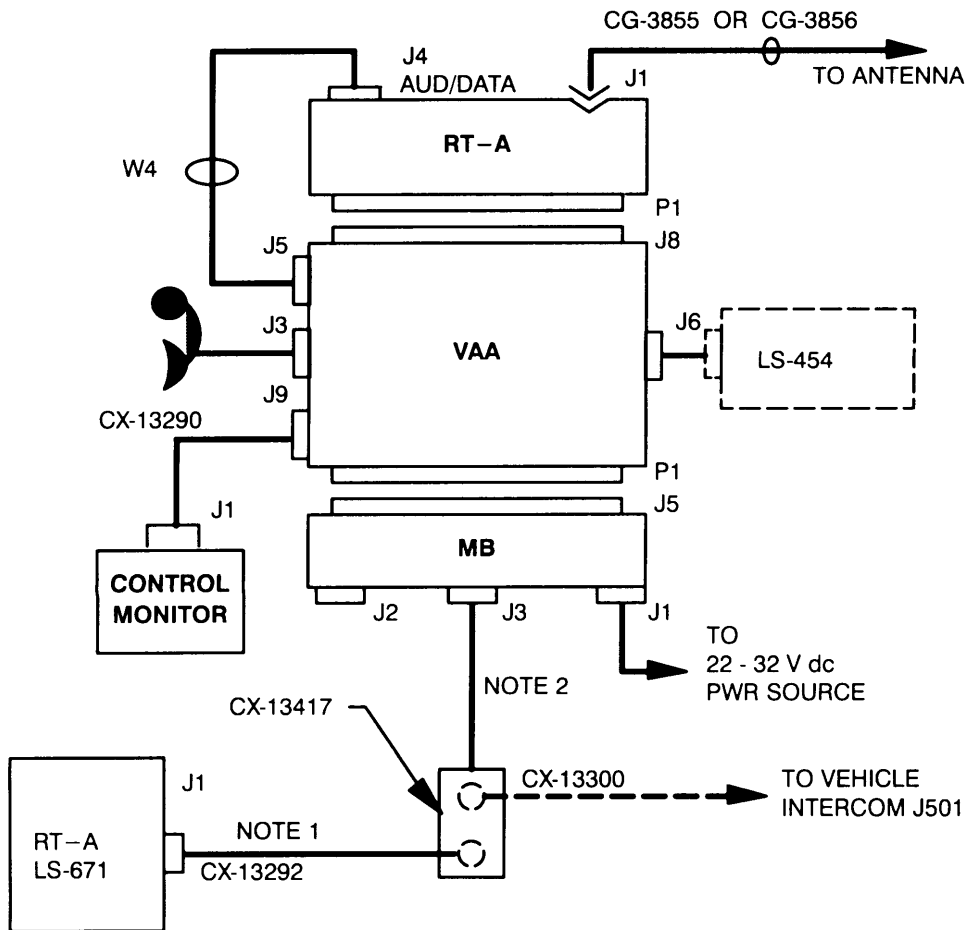

NOTES:

1. If the splitter cable (CX-13417) is not present, the loudspeaker cable (CX-13292) may be connected directly to J3, or the vehicle intercom may be connected to J3 via the VIC interface cable (CX-13313).
2. CX-13292 and CX-13300 may be connected to either mating connector of CX-13417.

SHORT RANGE / RT (A)

5.10. SHORT RANGE RADIO/RT (B)

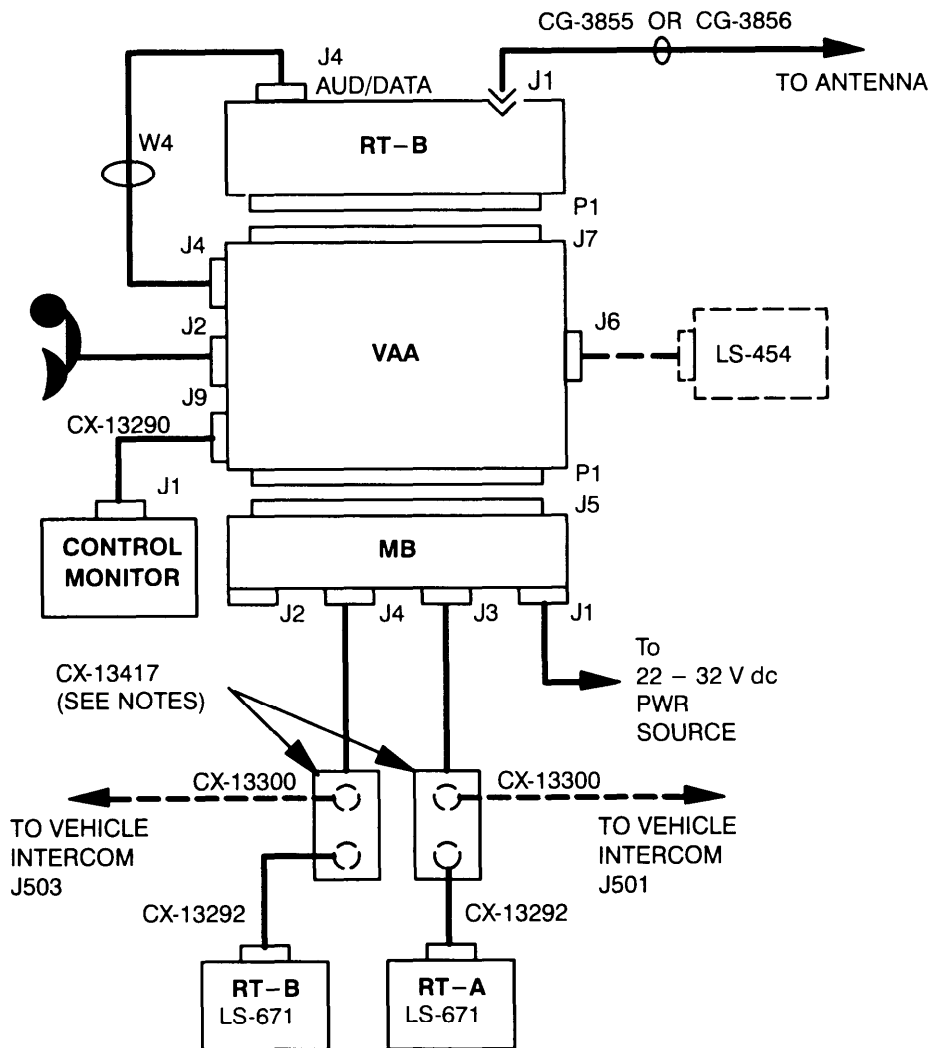

NOTES:

1. If the splitter cables (CX-13417) are not present, the loudspeaker cables (CX-13292) may be connected directly to J3 and J4, or the intercom cables (CX-13300) may be connected to J4 and to J3 via VIC interface cable (CX-13313).
2. CX-13292 and CX-13300 may be connected to either mating connector of CX-13417.
3. RT-A cabling shown strictly for troubleshooting a power failure.

SHORT RANGE / RT (B)

5.11. LONG RANGE RADIO/RT (A)

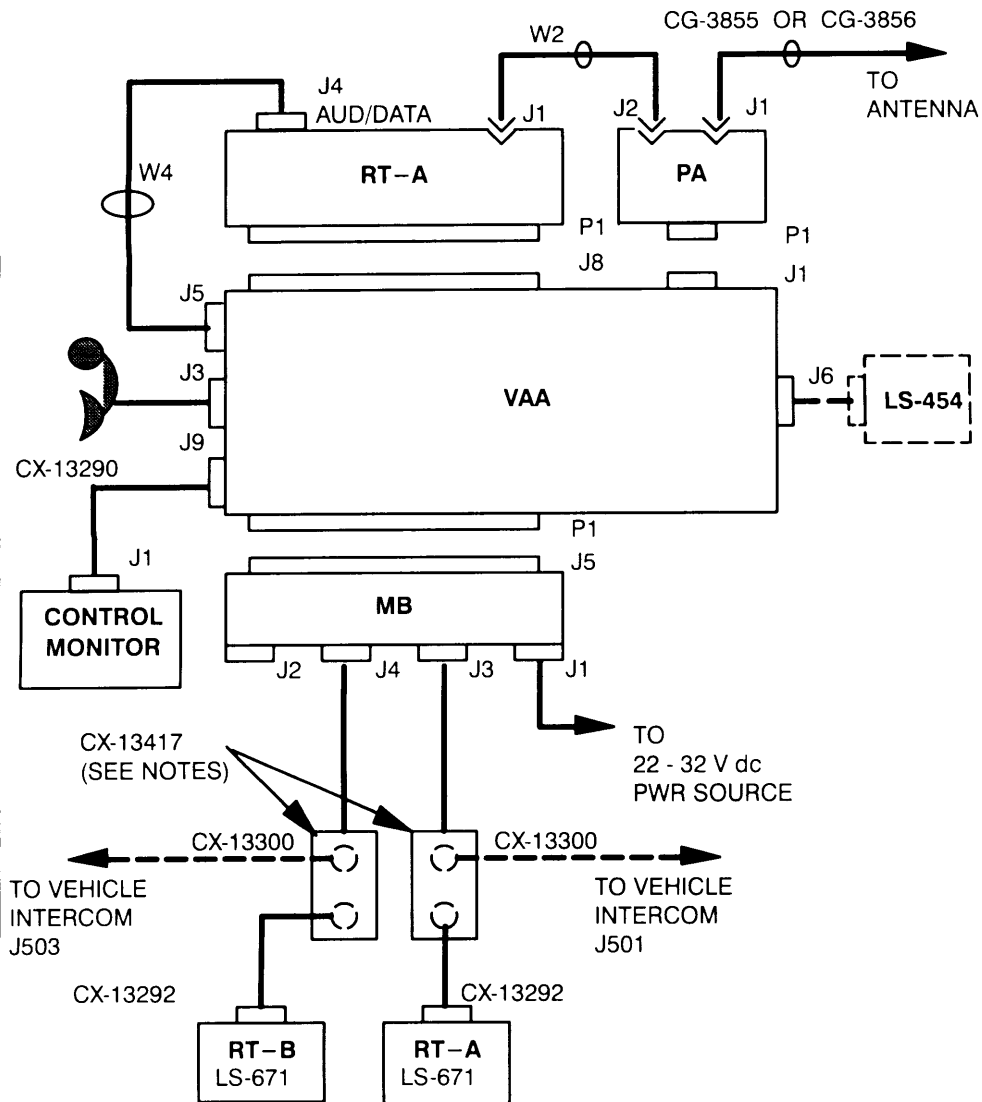

NOTES:

1. If the splitter cables (CX-13417) are not present, the loudspeaker cables (CX-13292) may be connected directly to J3 and J4, or the intercom cables (CX-13300) may be connected to J4 and to J3 via VIC interface cable (CX-13313).
2. CX-13292 and CX-13300 may be connected to either mating connector of CX-13417.
3. RT-B cabling shown strictly for troubleshooting a power failure.

LONG RANGE / RT (A)

5.12. LONG RANGE RADIO/RT (B)

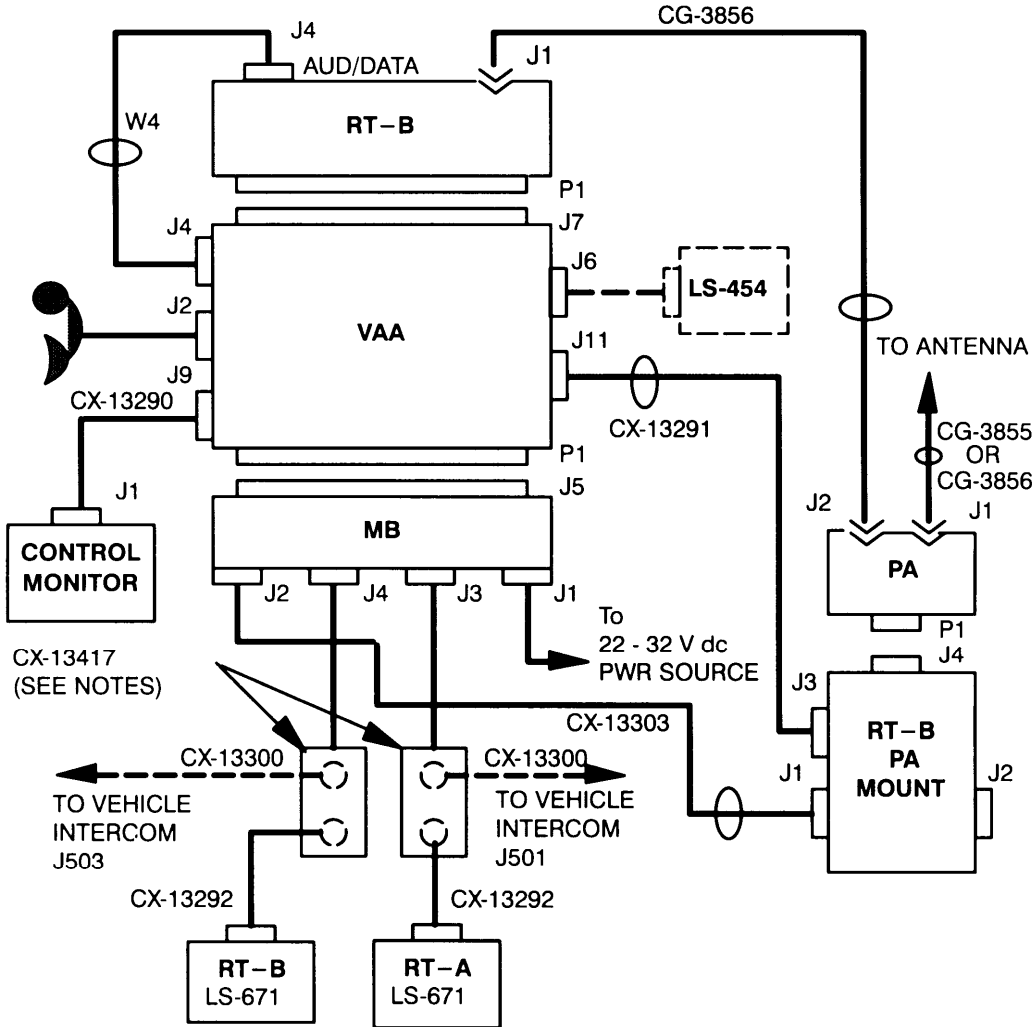

NOTES:

1. If the splitter cables (CX-13417) are not present, the loudspeaker cables (CX-13292) may be connected directly to J3 and J4, or the intercom cables (CX-13300) may be connected to J4 and to J3 via VIC interface cable (CX-13313).
2. CX-13292 and CX-13300 may be connected to either mating connector of CX-13417.
3. RT-A cabling shown strictly for troubleshooting a power failure.

LONG RANGE / RT (B)

THIS PAGE INTENTIONALLY BLANK.

SUBJECT	PAGE
Abbreviations Used	1-4
Audio/Data Cable	4-12
Avoiding False Pulls	1-2
Basis of Issue	1-1
COMSEC Alarm Not Heard/Clear	3-13,3-14
Control-Monitor	5-4
Destruction of Electronic Mat	1-3
Digital Adapter Cable	4-12
DMD (Data) Cable	4-8
Failed FWD & RVS Power Check	3-16
FWD PWR Incorrect Thru PA, RF PWR HI	3-17
Goal	1-1
Handset Graphic	5-5
How to Use Handbook	1-1
HYX-57 Cable	4-8
Intercom Cable	4-4
Introduction	1-1
Less Than 30W FWD PWR	3-18,3-19,3-20
Load Checks, Op Check.	2-2,3-3
Locating Subjects	1-1
Long Range RT-A-Schematic	5-8
Long Range RT-B Schematic.	5-9
Loss of Sidetone	2-6,3-16
Loudspeaker,CLS-671 Graphic	5-5
Low or No Power Output	2-5
LS-671 Cable	4-3
LS-671 Checks, OpCheck	3-7
M551 Power Cable	4-5
Maint Forms, Records, Reports.	1-2
Manpack Operational Check	2-1
Mounting Base Graphic.	5-2
MST-20 Adapter Cable	4-9
No Remote Power From RT-BLS-671	3-11
No Sidetone, FWD/RVS PWR OK	3-16
No Sidetone Heard at LS-671	3-23
PA Control Cable	4-3
PA Mt CB1 Trips, VAA DS1 is Lit.	3-11

SUBJECT	PAGE
PA Mt DS1 Not Lit,V/-WDS1 is Lit.	3-12
Points to Remember	3-1
Power Amplifier Checks, Op Check	3-6
Power Cable	4-5,4-6,4-7,4-11
Power Checks, Op Check	2-1,3-2
Preparation, Op Check	2-1,3-1
PSC-3 Adapter Cable	4-9
Purpose	1-1
Receiver Checks, Op Check	2-4,3-5
Receiver-Transmitter Graphic	5-3
Remote Control Unit Graphic	5-4
Reporting Eqpt Improvement Recs	1-3
Reporting Errors	1-3
RF Cable Schematic	4-2
RF Cable and W2 Schematic	4-2
RF Power Amplifier Graphic	5-3
RT Display Not Lit,VAA DS1 is Lit	3-12
RT Display Reads FAIL 6	3-13
RT Self-Test, Op Check	2-2, 3-3
RT-A LS-671 DS1 Not Lit, VAA DS1 is Lit	3-10
RXMT Cable.	4-4
Scope	1-2
Security Class & Marking	1-3
Short Range RT-A Schematic	5-6
Short Range RT-B Schematic	5-7
SIG Display Incorrect in PA	3-21
SIG Display Not Lit, LS-671 PTT	3-22
Splitter Cable	4-1 1
TACFIRE Magic Cable	4-10
Transmitter Checks, Op Check	2-3, 3-4
Typical SC Test Setup	3-5
VAA DS1 Not Lit, CB1 is ON	3-9
VAA CB1 Trips When Set to ON	3-8
Variable Will Not Load	2-5, 3-15
Vehicular Amplifier Adapter Graphic	5-2
Vehicular Radio Op Check	3-1
VIC Interface Cable	4-10
Will Not Operate w/Data Devices	2-6, 3-23

THIS PAGE INTENTIONALLY BLANK.

By Order of the Secretary of the Army:

GORDON R. SULLIVAN
General, United States Army
Chief of Staff

Official

MILTON H. HAMILTON
Administrative Assistant to the
Secretary of the Army

DISTRIBUTION:

To be distributed in accordance with DA Form 12-51-E,
block 1756 requirements for TM 11-5820-800-20-3.

RECOMMENDED CHANGES TO EQUIPMENT TECHNICAL PUBLICATIONS



SOMETHING WRONG WITH THIS PUBLICATION

THEN ... JOT DOWN THE DOPE ABOUT IT ON THIS FORM. CAREFULLY TEAR IT OUT. FOLD IT AND DROP IT IN THE MAIL.

FROM: (PRINT YOUR UNIT'S COMPLETE ADDRESS)
 Commander
 Stateside Army Depot
 ATTN: AMSTA-US
 Stateside, N.J. 07703-5007

DATE SENT
 10 July 1975

PUBLICATION NUMBER: **TM 11-5840-340-12** PUBLICATION DATE: **23 Jan 74** PUBLICATION TITLE: **Radar Set AN/PRC-76**

BE EXACT PIN-POINT WHERE IT IS				IN THIS SPACE TELL WHAT IS WRONG AND WHAT SHOULD BE DONE ABOUT IT:
PAGE NO	PARA-GRAPH	FIGURE NO	TABLE NO	
2-25	2-28			<p>Recommend that the installation antenna alignment procedure be changed throughout to specify a 2° IFF antenna lag rather than 1°.</p> <p>REASON: Experience has shown that with only a 1° lag, the antenna servo system is too sensitive to wind gusting in excess of 25 knots, and has a tendency to rapidly accelerate and decelerate as a result, causing strain to the drive train. Hunting is minimized by adjusting the lag to 2° without degradation of operation.</p>
3-10	3-3		3-1	<p>Item 5, Functional Test. Change "2 dB" to "3 dB".</p> <p>REASON: The adjustment procedure for the TRANS POWER FAULT indicator calls for a 3 dB (500 watts) adjustment to light the TRANS POWER FAULT indicator.</p>
5-6	5-8			<p>Add new step e.1 to read, "Replace cover plate removed in step e.1, above."</p> <p>REASON: To replace the cover plate.</p>
		FO-3		<p>Zone C 3. On J1-2, change "+24 VDC" to "+5 VDC".</p> <p>REASON: This is the output line of the 5 VDC power supply. +24 VDC is the input voltage.</p>

TEAR ALONG DOTTED LINE

SAMPLE

PRINTED NAME, GRADE/TITLE AND TELEPHONE NUMBER
 SSG I. M. DeSpirito 999-1776

SIGN HERE

DA FORM 2028-2
 1 JUL 79

PREVIOUS EDITIONS ARE OBSOLETE

PS. - IF YOUR OUTFIT WANTS TO KNOW ABOUT YOUR RECOMMENDATION MAKE A CARBON COPY OF THIS AND GIVE IT TO YOUR HEADQUARTERS.

RECOMMENDED CHANGES TO EQUIPMENT TECHNICAL PUBLICATIONS



SOMETHING WRONG

WITH THIS PUBLICATION

THEN ... JOT DOWN THE DOPE ABOUT IT ON THIS FORM. CAREFULLY TEAR IT OUT. FOLD IT AND DROP IT IN THE MAIL.

FROM: (PRINT YOUR UNIT'S COMPLETE ADDRESS)

DATE SENT

PUBLICATION NUMBER
TM
11-5820-890-20-3

PUBLICATION DATE
MARCH 1994

PUBLICATION TITLE
UNIT LEVEL MAINTENANCE HANDBOOK
SINCGARS ICOM GROUND RADIO

BE EXACT PIN-POINT WHERE IT IS

PAGE NO PARA-GRAPH FIGURE NO TABLE NO

IN THIS SPACE TELL WHAT IS WRONG AND WHAT SHOULD BE DONE ABOUT IT:

TEAR ALONG DOTTED LINE

PRINTED NAME, GRADE/TITLE AND TELEPHONE NUMBER

SIGN HERE

DA FORM 2028-2
1 JUL 7

PREVIOUS EDITIONS
ARE OBSOLETE

PS. - IF YOUR OUTFIT WANTS TO KNOW ABOUT YOUR RECOMMENDATION MAKE A CARBON COPY OF THIS AND GIVE IT TO YOUR HEADQUARTERS.

REVERSE OF DA FORM 2028-2

FILL IN YOUR UNIT'S
ADDRESS

FOLD BACK

DEPARTMENT OF THE ARMY

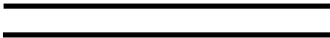

OFFICIAL BUSINESS

**U.S. Army CECOM
ATTN: AMSEL-LC-LM- LT
Fort Monmouth, New Jersey 07703-5007**

TEAR ALONG DOTTED LINE

RECOMMENDED CHANGES TO EQUIPMENT TECHNICAL PUBLICATIONS

SOMETHING WRONG

WITH THIS PUBLICATION?



THEN . . . JOT DOWN THE DOPE ABOUT IT ON THIS FORM, FOLD IT, AND DROP IT IN THE MAIL!

FROM: (PRINT YOUR UNIT'S COMPLETE ADDRESS)

DATE SENT

PUBLICATION NUMBER

PUBLICATION DATE

PUBLICATION TITLE

BE EXACT . . . PIN-POINT WHERE IT IS

IN THIS SPACE TELL WHAT IS WRONG AND WHAT SHOULD BE DONE ABOUT IT:

PAGE NO.

PARA-GRAPH

FIGURE NO.

TABLE NO.

PRINTED NAME, GRADE OR TITLE, AND TELEPHONE NUMBER

SIGN HERE

PIN: 073598-000